

LARRY W. WILSON

# Ezekiel



# Ezekiel

*Transcription*  
*of*  
Larry  
Wilson

God Intended to Transform a Nation

# Ezekiel

Copyright © 2024

First Edition, January 2024 / All rights reserved.

ISBN: 978-0-9848102-5-3

Scriptural quotations are taken from The Holy Bible: New International Version® NIV® Copyright© 1973 1978 1984 2011 by Biblica, Inc.™ / & / New Living Translation, copyright © 1996, 2004, 2015 by Tyndale House Foundation.

Used by permission.

*You will notice a substantial portion of this book uses the NLT instead of Larry's preferred NIV. There are two reasons for this: (1) So many verses are quoted in this book that to stay clear of copyright infringement an additional source for text is used. (2) The NLT was chosen for its readability. Stories simply sound better read from the NLT.*

## Larry W. Wilson

Wake Up America Seminars, Inc.  
P.O. Box 273, Bellbrook, Ohio 45305  
(800) 475-0876

*On occasion italics and brackets in Scripture quotations have been added to enhance understanding. They are not intended to change the meaning of the texts, only to clarify. We encourage you to consider them and hope they will provide you with deeper insight as you study God's Word.*

Illustrations by Polina Hrytskova

Dedicated to the memory of Larry W. Wilson. How I wish he could see the work of his lifetime published in the Transcript Series books.

## Acknowledgments

Thank you to all who support this ministry so faithfully. The Transcript Series books wouldn't be possible without your generosity. A very special thank you also goes to Eunice Leech who labored to meticulously and painstakingly edit and proof this manuscript line by line. I hope the end result is worth her immense effort.

Rex Johnson

books by  
Larry W. Wilson

Isaiah (2023)

Hebrews (2023)

Righteousness By Faith (2021)

The Untold Story of Jesus (2019)

No More Delay (2018)

The Lamb's Book of Life (2016)

Jesus' Final Victory (2011)

Daniel Unlocked For the Final Generation (2003)

Bible Stories with End Time Parallels (2002)

Warning! Revelation is About to be Fulfilled (1989)



# Table of Contents

Introduction .....	<i>1</i>
A Magnificent Vision .....	<i>15</i>
God Redefined Israel.....	<i>29</i>
Nobody Is Listening .....	<i>51</i>
Zedekiah The Weasel .....	<i>73</i>
Israel's Cup Of Iniquity.....	<i>95</i>
God Changed Plans.....	<i>111</i>
Israel's Apostasy .....	<i>125</i>
Temple Services .....	<i>141</i>





# Introduction

My purpose in writing this isn't to go through the book of Ezekiel and tell you what to believe it means. More importantly, I want to give enough information about Ezekiel so as you read his entire book, you can understand what it means for yourself. My goal is to give you tools to work with; thus, I have selected the chapters and sections I believe will help most. But don't accept anything because I say it. Read your own Bible and see what it says. Let the Spirit guide you into all truth. Examine it, consider it, and be like the noble Thessalonians in Berea. They didn't believe what Paul was preaching until they searched the Scriptures to see if his statements were true. I encourage you to do the same.

The book of Ezekiel is divided into three sections. Chapters 1–24 explain why the captives are in Babylon. God has a way of measuring wickedness called the full cup principle. It is the idea that every nation is granted a period of time to exist; and as long as that nation upholds principles of right-doing, the nation will be blessed. But sometimes the sins of earlier generations fill this cup so those being hammered may not understand why God is doing what He's doing when the time comes for punishment.

When the Children of Israel left Egypt and stayed in the desert forty years, only the younger generation entered the Promised Land. Moses spent much time in the Book of Deuteronomy recounting why the older generation didn't make it. Unfortunately, this didn't have a positive influence on the new generation, and the Book of Judges describes Israel going through seven periods of apostasy, repentance, and rebellion.

This is the case in Ezekiel. The Israelite captives who could

a messianic promise predicting the birth of the Messiah, Jesus. (Genesis 22:18)

(2) That his descendants would be more numerous than the stars of the sky. This is a lot of descendants for a man who has no children. (Genesis 15:5)

(3) That these descendants would someday inherit a certain geographical piece of land. (Genesis 15:18–21)

God made these promises simply because He loved Abraham. Abraham didn't have to do or agree to anything; it wasn't a mutual covenant, it was one-sided.

Incidentally, this is the same kind of covenant God made with man after the flood. He promised never to do it again and placed a sign in the sky in the form of a rainbow so that we would remember his promise. Man has no input, it is non-negotiable, it cannot be broken. Marriage on the other hand is a bilateral covenant—a mutual agreement having two parties.

God told Abraham that He would put this covenant in motion after his descendants had been in Egypt four hundred years.

**“Then the Lord said to him, ‘Know for certain that for four hundred years your descendants will be strangers in a country not their own and that they will be enslaved and mistreated there. But I will punish the nation they serve as slaves, and afterward they will come out with great possessions. You, however, will go to your ancestors in peace and be buried at a good old age. In the fourth generation your descendants will come back here, for the sin of the Amorites has not yet reached its full measure.’ When the sun had set and darkness had fallen, a smoking firepot with a blazing torch appeared and passed between the pieces.”** (Genesis 15:13–17)

Did you notice the operation of the full cup principle? Abraham was living in the land of Canaan when this unilateral covenant was made, but the Amorites possessed the land. The

Lord was waiting for the Amorite's sin to reach its full measure.

About the time the Amorites were exhausting the grace given them as a nation, God raised Moses to lead Abraham's descendants out of slavery to occupy the land. But the Amorites slipped into decadence and degeneracy as all nations do.

Why were the Amorites destroyed? Moses told the Israelites, **“Do not have sexual relations with a man as one does with a woman; that is detestable. Do not have sexual relations with an animal and defile yourself with it. A woman must not present herself to an animal to have sexual relations with it; that is a perversion. Do not defile yourselves in any of these ways, because this is how the nations that I am going to drive out before you became defiled. Even the land was defiled; so I punished it for its sin, and the land vomited out its inhabitants. But you must keep my decrees and my laws. The native-born and the foreigners residing among you must not do any of these detestable things, for all these things were done by the people who lived in the land before you, and the land became defiled. And if you defile the land, it will vomit you out as it vomited out the nations that were before you.”** (Leviticus 18:22–28)

Leviticus 18 states explicitly what constitutes sexual immorality. This type of behavior is the primary cause nations are expelled from their land. The Amorites lost their land because of it. And God warned Israel of the same consequence if they practiced the same degenerate behavior.

God said, **“Everyone who does any of these detestable things—such persons must be cut off from their people. Keep my requirements and do not follow any of the detestable customs that were practiced before you came and do not defile yourselves with them. I am the Lord your God.”** (Leviticus 18:29–30)

In Leviticus 25:23, God makes a statement that preachers don't say much about today. This conditional possession of the land is a critical part of understanding what Ezekiel was doing

in Babylon. **“The land must not be sold permanently, because the land is mine and you reside in my land as foreigners and strangers.”**

Possession of God’s land is conditional. God wanted a nation of priests, a people with the faith of Abraham, to be ambassadors of God’s goodness to the world. Exodus 19:1–6 says that God chose Israel to serve the human race on His behalf. The Israelites were to stand before the world as His representatives.

Paul says in Acts 13:47, **“For this is what the Lord has commanded us: ‘I have made you a light for the Gentiles, that you may bring salvation to the ends of the earth.’”**

The *us* Paul is referring to is the nation of Israel. Israel’s purpose from the beginning—and God’s singular reason for choosing them—was to bring the knowledge of salvation to the ends of the earth. In order to achieve this, God placed Israel in the middle of all nations so that everyone could hear about His salvation.

Ezekiel 5:5, **“This is what the Sovereign Lord says: This is Jerusalem, which I have set in the center of the nations, with countries all around her.”**

With Israel geographically in the center of the world, all who traveled through that region would have a chance to hear about God’s goodness, mercy, love, law, and salvation. But that didn’t happen.

Ezekiel 5:6–7, **“Yet in her wickedness she has rebelled against my laws and decrees more than the nations and countries around her. She has rejected my laws and has not followed my decrees. Therefore this is what the Sovereign Lord says: You have been more unruly than the nations around you and have not followed my decrees or kept my laws. You have not even conformed to the standards of the nations around you.”** Israel sank to an all-time low, hit bottom, and kept digging.

Ezekiel 5:8–9, **“Therefore this is what the Sovereign Lord says: I myself am against you, Jerusalem, and I will inflict punishment on you in the sight of the nations. Because of all your detestable idols, I will do to you what I have never done before and will never do again.”**

Israel became so degenerate, so apostate, that God eventually could do nothing with them. They had sunk to a condition from which there was no return. Complete destruction was the only solution.

This is what happened in Noah’s day. If God could have saved the world then, He would have. But the people would not turn from their degeneracy, even though the Holy Spirit contended with them for one hundred twenty years. This explains the rise and fall of nations. God takes them down when they become so degenerate that He cannot reach them.

God told the Jews they had so corrupted His reputation among the surrounding nations that He would destroy the land, Jerusalem, and Solomon’s temple, and then start over. Were it not for God’s covenant with Abraham, He would have totally abandoned Israel at that time. He came close to doing this on Mt. Sinai when He gave Moses the Ten Commandments and the waiting Israelites began dancing around the golden calf below.

The story is in Exodus 32.

God told Moses that He would destroy the current group of people and raise up another to carry on the fulfillment of the covenant. But Moses interceded by saying, “No, please, don’t do that. If you destroy your people then everyone will laugh at us—and they’ll laugh at you.” So God relented.

After the Exodus, God invited Israel to enter into a bilateral covenant upon which they mutually agreed. This covenant was, “If you will love and obey me with all your heart, then I will be your God.” Read about this in Exodus 6 and Jeremiah 7.

God intended the nation of Israel to develop into a superior

people reflecting His character in a world darkened by the degeneracy of sin. It was to be a light to the rest of the world. The Israelites were to be known as children of God so that the Gentiles, looking at Israel, could observe what God was like. (Exodus 19:5)

God wanted to transform a nation of slaves into a godly people. It was to be an example of how He could transform anyone. As promised, Abraham would be the father of many nations. The tribe of Levi was to be to the nation of Israel, what the nation of Israel was to be to the world. Israel was to be God's clergy to the Gentiles.

A profoundly important part of Ezekiel's story occurred before Ezekiel was even born; and it's the ongoing problem of why Ezekiel was confronting his people. That story is found in 2 Chronicles 24:19. Although the Lord sent many prophets to bring His people back to Him, they would not listen.

From the offering of the covenant at Mt. Sinai in 1437 BC until Ezekiel was taken prisoner in 598 BC, the people kept rebelling against the Lord. If we don't understand God's purpose and plan for Israel, and why the covenant was given, what Ezekiel says will be distorted. We must realize what is really going on and why it happened.

Today, statements in the Book of Ezekiel are lifted out of their historical context and used for conclusions that have nothing to do with God's intended meaning.

Refer to the timeline in drawing 0.1 as you read. The overview is important. If we don't understand how the timing works, it will eventually become a problem as weird ideas begin to form.

Moses led the children of Israel out of Egypt on the 15<sup>th</sup> day of the 1<sup>st</sup> month in 1437 BC. After 40 years of wandering in the wilderness because of unbelief, Israel entered Canaan in 1397 BC—exactly 40 years to the very day of leaving Egypt. After the new generation entered Canaan, Israel continuously went

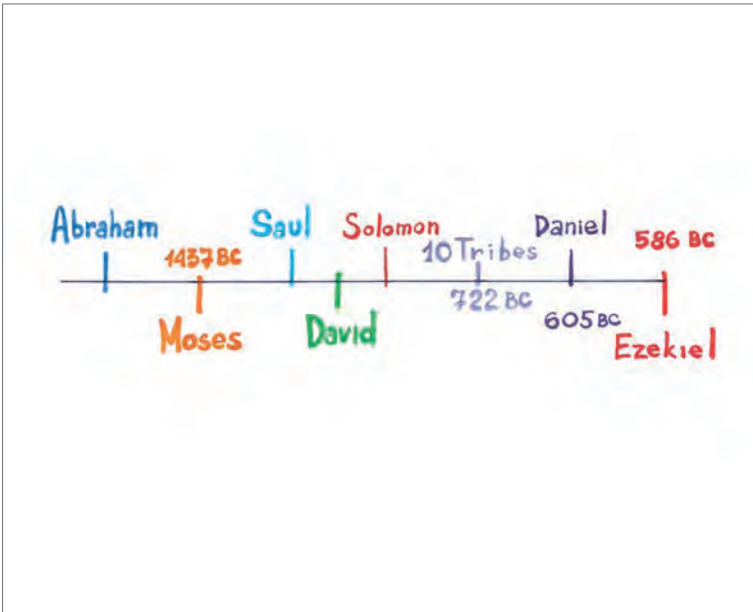

*Drawing 0.1*

After Solomon's reign, the country split into two nations because of heavy taxation. He decimated the country to pay for his extravagant behavior, such as feeding, clothing, and housing a thousand women!

After Solomon's death, his son Rehoboam (an idiot) would not relieve the people from the high taxes. In fact, he raised them even higher. So in 921 BC, ten of the northern tribes seceded, leaving two tribes in the south. The ten northern tribes are referred to as Israel, and the two southern tribes as Judah. Rehoboam tried to subdue the ten northern tribes, but God told him to leave them alone. (1 Kings 12:24) Rehoboam, however, remained ruler over the two southern tribes; Jeroboam, a bright administrator under Solomon, was made king over the northern tribes.

Jeroboam had two problems. First, all male Israelites were required to go to Jerusalem (in the south) three times a year: for Passover, Pentecost, and the Feast of Tabernacles.



Second, the high priest was located in Jerusalem but favorable to Rehoboam. To resolve these problems, Jeroboam created a look-a-like religion for the northern tribes so they would not need to go to Jerusalem.

**“Jeroboam thought to himself, ‘The kingdom will now likely revert to the house of David. If these people go up to offer sacrifices at the temple of the Lord in Jerusalem, they will again give their allegiance to their lord, Rehoboam king of Judah. They will kill me and return to King Rehoboam.’ After seeking advice, the king made two golden calves. He said to the people, ‘It is too much for you to go up to Jerusalem. Here are your gods, Israel, who brought you up out of Egypt.’ One he set up in Bethel, and the other in Dan. And this thing became a sin; the people came to worship the one at Bethel and went as far as Dan to worship the other. Jeroboam built shrines on high places and appointed priests from all sorts of people, even though they were not Levites. He instituted a festival on the fifteenth day of the eighth month, like the festival held in Judah, and offered sacrifices on the altar. This he did in Bethel, sacrificing to the calves he had made. And at Bethel he also installed priests at the high places he had made. On the fifteenth day of the eighth month, a month of his own choosing, he offered sacrifices on the altar he had built at Bethel. So he instituted the festival for the Israelites and went up to the altar to make offerings.”**  
(1 Kings 12:26–33)

Well, the people fell for it. They liked the convenience. The apostasy brought on by Jeroboam is important to heed because just two hundred years after Solomon’s death, God destroyed them because of it.

Prior to this God had sent Israel nine prophets: Ahijah, Amos, Elijah, Elisha, Hosea, Iddo, Jehu, Jonah, and Micaiah. As an object lesson to Israel, God sent Jonah to Nineveh to warn them He would destroy them unless they repented. Ultimately, Nineveh was destroyed since their repentance and

transformation didn't last. Likewise, God repeatedly warned Israel of its apostasy and of His forthcoming judgments if they didn't repent. God even sent a few prophets up from the south to warn those in the north, but they were ridiculed or tortured. A terrible life to live, wouldn't you say?

Assyria eventually relocated or destroyed the ten northern tribes in 722 BC for their apostasy. A tragic end for a people God wanted to do so much through.

**“The king of Assyria deported Israel to Assyria and settled them in Halah, in Gozan on the Habor River and in towns of the Medes. This happened because they had not obeyed the Lord their God, but had violated his covenant—all that Moses the servant of the Lord commanded. They neither listened to the commands nor carried them out.”** (2 Kings 18:11–12)

This purging of the land happened after they had disobeyed God by violating His covenant. Their conquest was a divinely ordained event. God's patience with Israel had run out, their cup had run over. Moses' warnings had come to pass.

We see this in our own country today. Regrettably, I believe the same consequence is coming. This nation, the United States of America, was blessed with immeasurable wealth and a constitution that is more valuable than all the money in the world. God has given this country every imaginable blessing. Yet, because of our sexual immorality, degeneracy, rebellion, and hegemonic ambitions, we too will meet destruction.

In my prophetic understanding, I believe America will fall. It will be brought to a position of helplessness. It will lose its military prowess, economic greatness, and be humbled before the world because as a nation, it has turned its back on the One who made it great.

In Leviticus, the Lord said, “The land is mine, you are but tenants.” Possession of the land was conditional on doing and following His will. Israel lost its inheritance. And the nation

never did fully repossess the land.

Seven hundred fifteen years transpired between the Exodus and the destruction of the ten northern tribes. There are two ways to look at this.

First, the historian's view looks at what happened from the human perspective. The Assyrians simply overpowered Israel and took possession of their land. Second, the spiritual view which the Bible clearly reveals from the cosmic perspective. God raised a destroyer to avenge the breaking of His covenant. Both views are accurate.

But those without spiritual eyesight can only see the historical view. The human response is to then build a stronger military. "Our strength is in the military." This view completely fails to acknowledge that God sets up kings and takes them down.

Meanwhile, down south, events of 2 Kings 21 were taking place. The two tribes in the south were following in the footsteps as their brothers in the north. Neither had spiritual eyes to see or spiritual ears to hear and refused to listen to the prophets. God grants every nation a cup of grace, and when that cup is filled, He destroys that nation.

Leviticus 26:27–33 says, **"If in spite of this you still do not listen to me but continue to be hostile toward me, then in my anger I will be hostile toward you, and I myself will punish you for your sins seven times over. You will eat the flesh of your sons and the flesh of your daughters. I will destroy your high places, cut down your incense altars and pile your dead bodies on the lifeless forms of your idols, and I will abhor you. I will turn your cities into ruins and lay waste your sanctuaries, and I will take no delight in the pleasing aroma of your offerings. I myself will lay waste the land, so that your enemies who live there will be appalled. I will scatter you among the nations and will draw out my sword and pursue you. Your land will be laid waste, and your cities will lie in ruins."**

The way God dealt with Israel and Judah mirrors how He deals with all nations. The Amorites and Israelites perished for the same reason. The Bible explains a course of human nature which historians do not acknowledge. For a better understanding of this principle, read Daniel 2 and 4 to learn how God consistently applies His regimen of discipline.

Let's go back to the south. About 700 BC, twenty-two years after the northern tribes had been destroyed, Judah was slipping into the same apostasy. God sent Habakkuk, Huldah, Isaiah, Jeremiah, Micah, Nahum, Oded, and Zephaniah to stir up the people in the south, but its decline continued. When Manasseh became king, the decline accelerated.

God sent nine prophets to the north and eight to the south, wanting the Israelites to do right. Jeremiah finally informed the Israelites that God's patience had run out. They had so corrupted God's reputation among surrounding nations that He would have to destroy Jerusalem. Sin eventually necessitates total destruction.

One hundred seventeen years after the north had been laid waste, Nebuchadnezzar attacked Jerusalem in 605 BC. The city wasn't destroyed completely in this first siege, only enough to control it and its people. It was at this time, Daniel, around eighteen years old, was taken to Babylon.

However, the Jews continued to be rebellious to God's authority, so Nebuchadnezzar returned in 598 BC more seriously damaging the city. It was during this attack that Ezekiel, about twenty-five years old, was taken to Babylon.

With Daniel and Ezekiel in Babylon, Nebuchadnezzar came back yet a third time in 586 BC; the people remaining in Judah were still being rebellious. This time though, he totally destroyed the city, the temple, and the land.

Jeremiah was in Jerusalem during this campaign but was forced into Egypt and died there. Incidentally, the ministry of Ezekiel was about forty-five years in length, Jeremiah about

fifty years, and Daniel about seventy.

This story began with Abraham and continued with his descendants at the Exodus in 1437 BC. The nine hundred years between the Exodus and Nebuchadnezzar's third siege, depicts the dismal history of Israel. However, if God had chosen another man, given the covenant to him, and chosen his descendants to fulfill His promises, the outcome would have been the same.

The biblical story of Israel is the story of all mankind. Israel was the spectacle in this story, but we're all players. Every nation would have responded the same way.

After Nebuchadnezzar's third destruction, God went through the process of restoring Israel to their land one last time—although they never will again receive the land with the borders it once had.

Today, a lot of people want to take the prophecies of Isaiah, Jeremiah, and Ezekiel, lift them out of the restoration that started with the 536 BC decree to rebuild Jerusalem, and move them down to the end of the world. The book of Ezekiel disputes this manipulation of scripture.

Follow the overview the Bible clearly lays out. When God brought about the destruction of Jerusalem, He had already destroyed Israel, and He had three prophets in place: Jeremiah in Jerusalem, Daniel in Babylon living in the king's court, and Ezekiel also in Babylon but laboring in the fields.

Through these three prophets, God was speaking to three groups: (1) one back home in Jerusalem, (2) one in Babylon, and (3) one that would return to Israel. This is the prophetic setting of the book of Ezekiel. God is using their unique ministries to do a particular work.

Because God has perfect foreknowledge, He had two prophets writing two scenarios. Ezekiel was writing about what was ahead for Israel in *Plan A*; Daniel was writing about what will happen at the end of the world in *Plan B*. The caveat being, if

Israel didn't cooperate during the allotted 490 years of the 70 weeks, Daniel's prophecies would then be implemented. If the returnees, however, cooperated and allowed God to do what He wanted through them, then the prophecies of Daniel would never be known.

Well, we've come to the end of the introduction. What have we learned thus far?

(1) We know God was patient with Israel's backsliding. Corporately speaking, God sent a total of 17 prophets.

(2) We know how and why Daniel and Ezekiel were in Babylon.

(3) We know why God raised up destroyers to eliminate Israel and Judah.

(4) We know the time frame of these events.

With this information, we are ready to begin studying Ezekiel.

## chapter 1



# A Magnificent Vision

Much mystery and misunderstanding surround the Book of Ezekiel. He was just thirty years old. A young man prepared to go to the elders of Israel and tell them what God had to say. From verse 2, we know the year was 593 BC, and the month was June or July, depending on the cycle of the moon.

Ezekiel 1:1–4 says, **“In my thirtieth year, in the fourth month [Tammuz] on the fifth day, while I was among the exiles by the Kebar River, the heavens were opened and I saw visions of God. On the fifth of the month—it was the fifth year of the exile of King Jehoiachin—the word of the Lord came to Ezekiel the priest, the son of Buzi, by the Kebar River in the land of the Babylonians. There the hand of the Lord was on him. I looked, and I saw a windstorm coming out of the north—an immense cloud with flashing lightning and surrounded by brilliant light. The center of the fire looked like glowing metal.”**

Ezekiel was watching this vision of a windstorm coming

out of the north. Zechariah also saw this windstorm which he called a whirlwind. **“I scattered them with a whirlwind among all the nations, where they were strangers. The land they left behind them was so desolate that no one traveled through it. This is how they made the pleasant land desolate.”** (Zechariah 7:14)

A search through the Bible shows divine destruction always came out of the north. Ezekiel mentioned the north, and Jeremiah also made reference to the north as the direction from which destruction comes.

**“The Lord said to me, ‘From the north disaster will be poured out on all who live in the land. I am about to summon all the peoples of the northern kingdoms,’ declares the Lord.”** (Jeremiah 1:14–15)

Back to Ezekiel, **“And in the fire was what looked like four living creatures. In appearance their form was human, but each of them had four faces and four wings. Their legs were straight; their feet were like those of a calf and gleamed like burnished bronze. Under their wings on their four sides they had human hands. All four of them had faces and wings, and the wings of one touched the wings of another. Each one went straight ahead; they did not turn as they moved. Their faces looked like this: Each of the four had the face of a human being, and on the right side each had the face of a lion, and on the left the face of an ox; each also had the face of an eagle.”** (Ezekiel 1:5–10)

These were strange-looking creatures. Their feet resembled the hoof of a calf. What do their faces represent? The lion is known to be fearless, the ox is known to be strong, man is known for his intellect, and the eagle is known for its ability to strike quickly.

Each creature had the same four faces. I don’t know if they were arranged as shown in drawing 1.1, but when Ezekiel looked at them, no matter where he was standing, he could see all four faces at the same time.



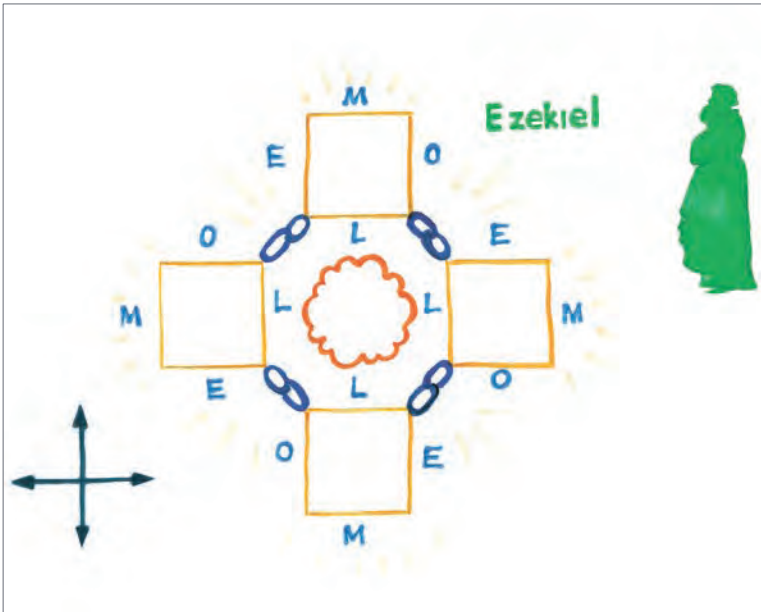

Drawing 1.1

In the middle of these creatures was a brilliant fire resembling glowing metal. The creatures also had four wings that touched each other. I am assuming when all four creatures spread their wings, their wing tips touched. When these creatures moved, they didn't turn, they remained facing forward. And they moved in every direction without turning their heads.

I need to explain who these four living creatures are and what they do. I believe these four identical creatures are a representation of the Holy Spirit. Now, don't throw the book down yet! I realize what I'm saying is controversial. It seems like everything I say falls into that category. But consider what the Bible says before coming to any conclusions.

In Bible prophecy, it is common for God to use an animal or symbol to represent some thing. In Revelation 12, the great red dragon has seven heads and ten horns. This represents the Devil. We know Satan doesn't look like that—he was created as

a beautiful angel. God describes him this way to teach us what we need to know. He often uses caricatures to represent what is too hard to define.

Ezekiel was describing four clones, four identical creatures, each having the same characteristics—intelligence, strength, fearlessness, and swiftness—attributes that belong to God alone. The vision shows that God is immortal, omnipotent, omniscient, and omnipresent. He can be everywhere at the same time. How can the Holy Spirit be in my home and yours at the same time? Jesus nor the Father can do that. Only the Holy Spirit can.

In drawing 1.2, Ezekiel was shown four characters to indicate the Holy Spirit is simultaneously at all four positions of the compass: N, S, E, and W.

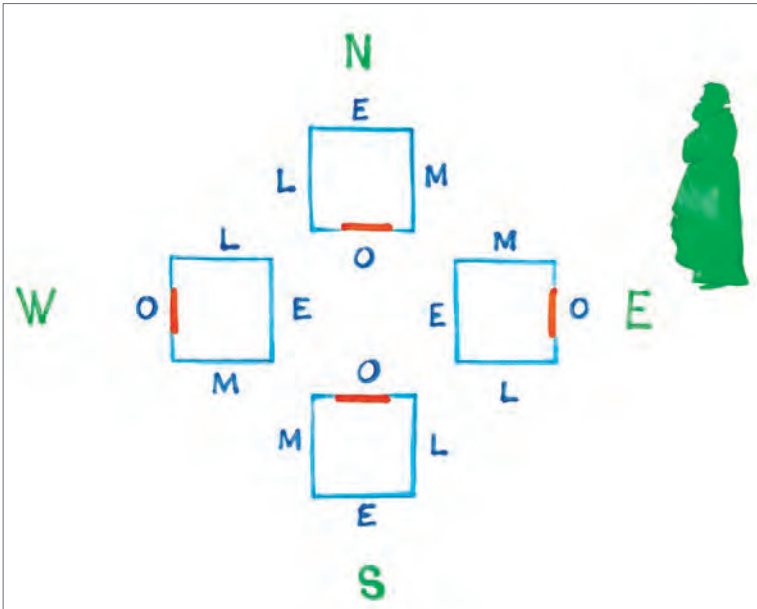

*Drawing 1.2*

The four faces were presented in such a way that Ezekiel might understand more about the Holy Spirit. How else would

you describe this ability so humans could understand it?

**Ezekiel 1:11–14, “Such were their faces. They each had two wings spreading out upward, each wing touching that of the creature on either side; and each had two other wings covering its body. Each one went straight ahead. Wherever the spirit would go, they would go, without turning as they went. The appearance of the living creatures was like burning coals of fire or like torches. Fire moved back and forth among the creatures; it was bright, and lightning flashed out of it. The creatures sped back and forth like flashes of lightning.”**

Notice how fast they are. When they move, there is no turning. They move in all directions without having to adjust. There are eyes all over these creatures. The text says they live among fire. This reminds me of the fiery furnace Nebuchadnezzar built to destroy the three Hebrews. But after throwing them in, Jesus was found standing in their midst. Who else but God can dwell in fire?

**Ezekiel 1:15–18, “As I looked at the living creatures, I saw a wheel on the ground beside each creature with its four faces. This was the appearance and structure of the wheels: They sparkled like topaz [golden stone], and all four [wheels] looked alike. Each appeared to be made like a wheel intersecting a wheel. As they moved, they would go in any one of the four directions the creatures faced; the wheels did not change direction as the creatures went. [The wheels spun but did not rotate based on their travel.] Their rims [around the edge of the wheels] were high and awesome, and all four rims were full of eyes all around.”**

The description sounds a bit like the symbol for atomic energy. The resemblance is shown in drawing 1.3. If electrons traveled around each wheel, we could see an optical illusion of what it would look like if they were spinning. Ezekiel is seeing that the energy of these four living creatures is in these wheels.

A circle is an interesting symbol for God. It has no

beginning or end; it completely encircles everything within its circumference and faces everything without. This circle of intersecting wheels implies the four creatures are not literal but a representation.

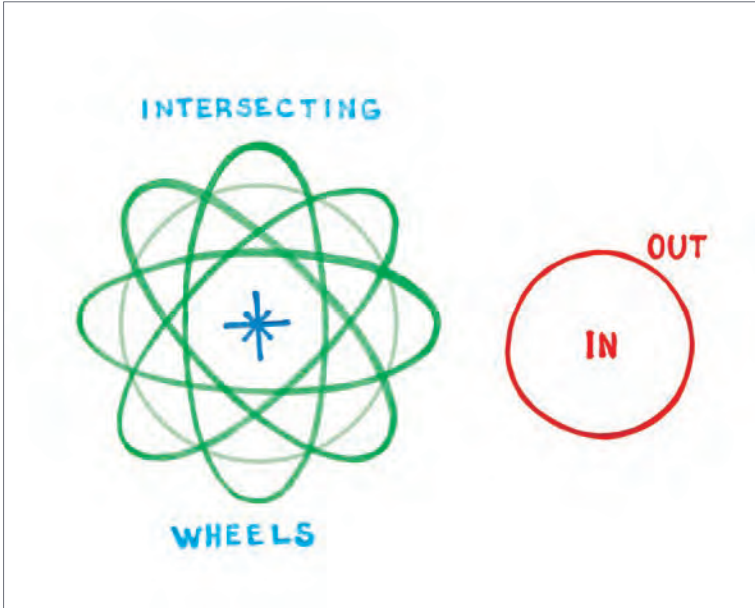

Drawing 1.3

In Chapter 10, Ezekiel heard them called *whirling wheels* because they didn't spin in accordance with the creatures movements. They remained spinning at all times. The presence of so many eyes suggests omniscience, conveying God's ability to see the entire universe. He sees everything, everywhere, at all times.

I believe there are three Gods: the Father, the Son, and the Holy Spirit. When baptized, we are baptized into all three because they are three distinct, separate entities called God. Some people believe there is one God and He goes by three names at different times. I don't believe the Bible teaches that! There are numerous verses that clearly reveal a Trinity. This caricature being shown to Ezekiel has a lot of meaning, and

God wants us to understand its message.

In this first chapter, God is introducing Ezekiel to the Spirit. The four living creatures found in Ezekiel are the same as found in Revelation 4, 5, and 6. John, when taken up to heaven, sees the four living creatures. God is revealing the mysterious attributes of the Holy Spirit which could not otherwise be known.

**“When the living creatures moved, the wheels beside them moved; and when the living creatures rose from the ground, the wheels also rose. Wherever the spirit would go, they would go, and the wheels would rise along with them, because the spirit of the living creatures was in the wheels. When the creatures moved, they also moved; when the creatures stood still, they also stood still; and when the creatures rose from the ground, the wheels rose along with them, because the spirit of the living creatures was in the wheels.”** (Ezekiel 1:19–21)

The word spirit means power or life or breath. The creatures’ power was in the wheels, which represents God’s power. Ezekiel said the life was in these spinning wheels and they exist apart from the body. This is a huge clue. These wheels are full of eyes and power. The power isn’t produced by the creatures, it comes from the wheels intersecting. It is the intersecting, the intertwining, the marriage of these wheels that produces the power. These wheels represent the authority, divinity, and power of the Trinity.

Imagine the difficulty Ezekiel was having putting this magnificent vision into words. God’s power doesn’t rest in a body like it does for humans. His authority can take any form. If God can speak through a donkey, there is nothing He can’t do. His power can empower anything.

**“Spread out above the heads of the living creatures was what looked something like a vault, sparkling like crystal, and awesome. Under the vault their wings were stretched out one toward the other, and each had two wings covering**

its body. When the creatures moved, I heard the sound of their wings, like the roar of rushing waters, like the voice of the Almighty, like the tumult of an army. When they stood still, they lowered their wings.” (Ezekiel 1:22–24)

Ezekiel is struggling to describe what he is seeing. It is so difficult. If you were standing in God’s presence, what words would you use?

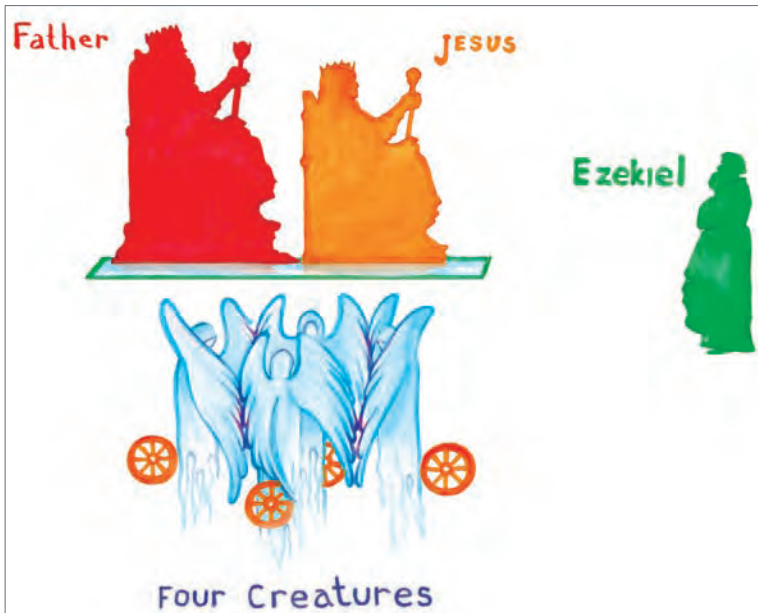

*Drawing 1.4*

Drawing 1.4 depicts the four creatures. Each one has a body, feet, and their wings touch. They stand under a large glass expanse on which Jesus sits on a big throne. Wherever these creatures go, they transport this glass deck. In Ezekiel’s time, kings were carried about on the shoulders of their most loyal servants. God represented His throne being carried by the four living creatures because the Holy Spirit is the servant side of the Trinity.

**“Then there came a voice from above the vault over their**

heads as they stood with lowered wings. Above the vault over their heads was what looked like a throne of lapis lazuli, and high above on the throne was a figure like that of a man. I saw that from what appeared to be his waist up he looked like glowing metal, as if full of fire, and that from there down he looked like fire; and brilliant light surrounded him. Like the appearance of a rainbow in the clouds on a rainy day, so was the radiance around him. This was the appearance of the likeness of the glory of the Lord. When I saw it, I fell facedown, and I heard the voice of one speaking.” (Ezekiel 1:25–28)

Jesus introduced Himself to Ezekiel, who fell on his face when he entered God’s presence. I have read the Bible many times over fifty years and haven’t seen an example of anyone dancing around when *in God’s immediate presence*. All who refer to being in the presence of God fall on their faces in fear and trembling. It is sad, but too often today, worship is about cheerleading—getting the adrenaline pumped up. Church services are now more pep rally than worship.

The Bible says, “It is better to obey than sacrifice.” When we come to the worship service, its design and purpose is to corporately drawn near to God, not be entertained. The deceit with this form of worship is, if done long enough, it soon becomes a requirement to feel close to God. I realize worship is personal, but God wants our worship not our cheers.

Back to Ezekiel’s vision. We know from the Book of Hebrews that the throne of God has two chairs. The Father sits in the center and Jesus sits to His right. The Father and Son share this throne, and the one who bears and carries the throne is the Holy Spirit. The text says the glory around Jesus was like the appearance of a rainbow in the clouds on a rainy day.

There is a deliberate reason God gave this representation of the Holy Spirit as four creatures to Ezekiel. The whole reason Ezekiel was in captivity was because Israel rejected the Spirit. So, the first thing Jesus shows Ezekiel is the Spirit of God and

its awesome powers. **“Not by might nor by power, but by my Spirit,’ says the Lord Almighty.”** (Zechariah 4:6)

The following verse reveals the role of the Holy Spirit. **“But when he, the Spirit of truth, comes, he will guide you into all the truth. He will not speak on his own; he will speak only what he hears, and he will tell you what is yet to come.”** (John 16:13)

He, the Holy Spirit, will not speak on His own. He could, but He doesn’t. Jesus didn’t guide the disciples into all truth, it wasn’t His mission.

The Holy Spirit is man’s only connection to God. If it weren’t for the Holy Spirit, we would not know God. Paul wrote, **“The person without the Spirit does not accept the things that come from the Spirit of God but considers them foolishness, and cannot understand them because they are discerned only through the Spirit.”** (1 Corinthians 2:14)

We cannot understand God without the Spirit, so spiritual matters are just foolishness. I know and love wonderful people who do not have the Holy Spirit controlling their lives. Spiritual things are foolishness to them because they have not allowed the Spirit to bring discernment. There are many people like this. This condition will ultimately cause the destruction of earth. Jesus told Nicodemus in John 3:6, **“Flesh gives birth to flesh, but the Spirit gives birth to spirit.”** We have to be transformed.

John 4:24 says, **“God is spirit, and his worshipers must worship in the Spirit and in truth.”** When you worship God, your spirit has to be in tune with God. There can be no separation. You must worship Him in truth. And if you aren’t doing all you know is right, you’re not worshipping Him in truth. Cheerleading doesn’t work. Truth is submitting to what is right and doing it.

1 Corinthians 2:11 says, **“For who knows a person’s thoughts except their own spirit within them? In the same**



**way no one knows the thoughts of God except the Spirit of God.”**

The three members of the Godhead have different roles. When we see Jesus in human flesh, we understand what God would do by studying the life of Christ. Jesus said, “If you’ve seen me, you’ve seen the Father.” People misinterpret that to mean that Jesus is the Father, but that is not the case. He is simply saying, “I’m a reflection of the Father. Look at me and study my life; you will understand what the Father is like.”

In a similar way, the Holy Spirit’s work is to represent the other two Gods. He is the means through whom their will is accomplished. For example, before the flood, when the Lord said, “My spirit will not contend with man forever,” it was the Holy Spirit contending with man. He was trying to get mankind to repent.

The three members of the Godhead are one in purpose, plan, and action. They are equal in every way. Yet, they serve in distinct roles so that an infinite Godhead can be understood by a finite creation. The God we call Father, serves as the Head of the universe. The God we call Jesus, serves as the creative agent of the Godhead. The God we call the Holy Spirit enables communication with the Godhead at all times.

Paul tells us in Romans 8:26, **“In the same way, the Spirit helps us in our weakness. We do not know what we ought to pray for, but the Spirit himself intercedes for us through wordless groans.”**

The Spirit Himself intercedes for us to Jesus and the Father. He is doing the intercessor work for the Godhead. At the same time, Jesus intercedes between the Father and the demands of the Law.

Because the Holy Spirit is the agency through whom God speaks to man, when the majority in Israel refused to obey the Spirit, apostasy resulted. God then cauterized Israel’s rebellion by sending destruction upon the nation. The resulting exile

was a direct result of refusing to listen to and obey the Holy Spirit. Matthew 12:31 says, **“And so I tell you, every kind of sin and slander can be forgiven, but blasphemy against the Spirit will not be forgiven.”**

Why is blasphemy against the Spirit unpardonable? Because man’s only connection to the Trinity is through the Spirit. If a person shuts out the Holy Spirit, no connection to the Father or Son exists. This was the deplorable condition of Israel in Ezekiel’s day.

Notice how Jesus tenderly spoke to Ezekiel. **“He said to me, ‘Son of man, stand up on your feet and I will speak to you.’ As he spoke, the Spirit came into me and raised me to my feet, and I heard him speaking to me.”** (Ezekiel 2:1–2)

The Holy Spirit lifted Ezekiel so he could hear Jesus.

Ezekiel 2:3–8, **“He said: ‘Son of man, I am sending you to the Israelites, to a rebellious nation that has rebelled against me; they and their ancestors have been in revolt against me to this very day. The people to whom I am sending you are obstinate and stubborn. Say to them, “This is what the Sovereign Lord says.” And whether they listen or fail to listen—for they are a rebellious people—they will know that a prophet has been among them. And you, son of man, do not be afraid of them or their words. Do not be afraid, though briars and thorns are all around you and you live among scorpions. Do not be afraid of what they say or be terrified by them, though they are a rebellious people. You must speak my words to them, whether they listen or fail to listen, for they are rebellious. But you, son of man, listen to what I say to you. Do not rebel like that rebellious people; open your mouth and eat what I give you.’ ”**

Jesus was saying, “Ezekiel, I want you to use my words, not yours.” Ezekiel is not going to be a preacher, he is going to be a prophet. There is a big difference between a preacher and a prophet.

A preacher is one who studies the Word and then teaches about it as he understands it. The preacher uses his own words as the Spirit guides him—as education and study lead him to understand the Word.

With a prophet it's very different. When God chooses a prophet, He gives the prophet words to speak. And when the prophet speaks those words, we can take them as being God's words, not his own.

There is an end-time parallel between Ezekiel's day and the end of the world. What Ezekiel was to the house of Israel, the 144,000 will be during the great tribulation. The 144,000 will have the same experience as Ezekiel. God will give them words to speak.

Ezekiel 2:9–10, **“Then I looked, and I saw a hand stretched out to me. In it was a scroll, which he unrolled before me. On both sides of it were written words of lament and mourning and woe.”**

This is not good news. When God raises a prophet to speak, the prophet never says anything pleasant therefore he isn't a popular guy. People in an apostate condition don't want to hear what a prophet has to say. The message is offensive. So they kill the messenger in order to silence the message. It will be the same during the great tribulation. Most of the 144,000 will die delivering the words of God to a world full of people who desperately need salvation but don't want to hear the message.

From Ezekiel's vision we see the work of the Holy Spirit is critical. He is all-seeing and all-knowing. The four living creatures Ezekiel saw are not men, they represent the Holy Spirit. The spinning wheels beside the creatures represent the God-head's power; their four faces represent strength, intelligence, swiftness, and fearlessness. Nowhere in the Bible does any other creature have these attributes. God kindly introduced Ezekiel to the Holy Spirit so we could know more about his role in the Trinity.



## chapter 2



# God Redefined Israel

Let's begin this chapter with Ezekiel 3:1–4. **“And he said to me, ‘Son of man, eat what is before you, eat this scroll; then go and speak to the people of Israel.’ So I opened my mouth, and he gave me the scroll to eat. Then he said to me, ‘Son of man, eat this scroll I am giving you and fill your stomach with it.’ So I ate it, and it tasted as sweet as honey in my mouth. He then said to me: ‘Son of man, go now to the people of Israel and speak my words to them.’”**

God was illustrating how His words were given to His prophets. After ingesting the words Ezekiel was instructed to pass them on to Israel's elders. This doesn't make everything Ezekiel wrote inspired, only the words God gave were inspired. I'm sure Ezekiel talked with friends and wrote letters that were his own words. I'm differentiating the words of God and the words of Ezekiel. As with all prophets, Ezekiel was the *arms and legs* of God's words.

You can only enter into this type of experience if you're

committed to God. Ezekiel was willing to obey God's call, thus the book was sweet as honey although God's words caused him great distress. This same language is used in Revelation 10.

The words of God are sweet to understand but delivering His message isn't always pleasant. It's a bitter experience to be rejected and ridiculed and condemned, because people don't want to hear what God has to say. God said, "If I had sent you to the Gentiles they would have listened." Here lies the problem: When we reject the Holy Spirit our heart becomes hardened.

**Ezekiel 3:5-11, "You are not being sent to a people of obscure speech and strange language, but to the people of Israel—not to many peoples of obscure speech and strange language, whose words you cannot understand. Surely if I had sent you to them, they would have listened to you. But the people of Israel are not willing to listen to you because they are not willing to listen to me, for all the Israelites are hardened and obstinate. But I will make you as unyielding and hardened as they are. I will make your forehead like the hardest stone, harder than flint. Do not be afraid of them or terrified by them, though they are a rebellious people.' And he said to me, 'Son of man, listen carefully and take to heart all the words I speak to you. Go now to your people in exile and speak to them. Say to them, "This is what the Sovereign Lord says," whether they listen or fail to listen.'"**

The bulk of Ezekiel's message was directed to his countrymen who were in exile. Today many Christians take Ezekiel's words out of context, moving their meaning to the end of time and applying them to an Israel that doesn't exist. But the book of Ezekiel belongs *exclusively* to his countrymen in exile at that time. His message must be understood in that setting. There is a time and place for what is predicted in the book of Ezekiel and it isn't at the end of the world. If prophecies are taken out of context and moved around, we make mud of God's word.

**Ezekiel 3:12-15, "Then the Spirit lifted me up, and I**

heard behind me a loud rumbling sound as the glory of the Lord rose from the place where it was standing. It was the sound of the wings of the living creatures brushing against each other and the sound of the wheels beside them, a loud rumbling sound. The Spirit then lifted me up and took me away, and I went in bitterness and in the anger of my spirit, with the strong hand of the Lord on me. I came to the exiles who lived at Tel Aviv near the Kebar River. And there, where they were living, I sat among them for seven days—deeply distressed.”

In Chapter 1, the Spirit bore up the great throne of God. Here, the Spirit is lifting up Ezekiel. What good would Ezekiel’s message do if there were no power behind it to penetrate rebellious hearts? God was giving Ezekiel His Spirit. Ezekiel was empowered and carried but the words came from Jesus. This is called the Spirit of Prophecy: the testimony of Jesus.

Ezekiel was overwhelmed with Israel’s despicable condition; like Moses when he came off the mountain and saw the Israelites worshiping the golden calf. Moses had been privileged to experience the righteousness and holiness of God, only to step out of that glorious cloud and see their degenerate behavior.

Ezekiel was willing to be used by the Lord, but when among the elders, he sat there overwhelmed for seven days without saying a word. He wasn’t one of them. He was young and didn’t know how to begin. Yet, God had chosen him to deliver a message of enormity. What was he to do?

After the seven days, the Lord came to Ezekiel and said, **“Son of man, I have made you a watchman for the people of Israel; so hear the word I speak and give them warning from me. When I say to a wicked person, ‘You will surely die,’ and you do not warn them or speak out to dissuade them from their evil ways in order to save their life, that wicked person will die for their sin, and I will hold you accountable for their blood.”** (Ezekiel 3:17–18)

Being a prophet had suddenly become serious! This was

why Paul later wrote, “Woe to me if I preach not the gospel.” Once you have been called and set apart to conduct His work, the responsibility is tremendous.

**Ezekiel 3:19, “But if you do warn the wicked person and they do not turn from their wickedness or from their evil ways, they will die for their sin; but you will have saved yourself.”**

The Lord was telling him, “It is your job to say what I want said. The consequences will be upon those who do not listen, but if you don’t speak, the consequences will be on your head.” Ezekiel quickly found that carrying out God’s word could be extremely bitter.

**Ezekiel 3:20–22, “‘Again, when a righteous person turns from their righteousness and does evil, and I put a stumbling block before them, they will die. Since you did not warn them, they will die for their sin. The righteous things that person did will not be remembered, and I will hold you accountable for their blood. But if you do warn the righteous person not to sin and they do not sin, they will surely live because they took warning, and you will have saved yourself.’ The hand of the Lord was on me there, and he said to me, ‘Get up and go out to the plain, and there I will speak to you.’”**

This suited Ezekiel just fine!

What does it mean for the Lord to put a stumbling block before him? It means, God takes responsibility for some of the obstacles we face. A righteous man can turn away from righteousness. A righteous man can begin to be evil. The once-saved, always-saved doctrine is not valid. When King Saul was anointed king he was initially a righteous man but then became evil, so God rejected him and gave the kingdom to David.

God didn’t create sin, it originated with Lucifer who is the father of sin. God doesn’t put sin before us. He places nothing before us that we can’t overcome through the power of the



Spirit. Albeit, God does test us. However, the responsibility for passing the test is ours. That is why living by faith is difficult and very few really can do it.

One example of being tested is the story of the Garden of Eden. The tree was put there to test Adam and Eve. And in Exodus 16, God sent no manna on the seventh day to test Israel. He wanted to see if they would keep His Sabbath. The history of Israel is a warning to each of us. God's words need to be taken seriously.

Ezekiel was so timid that he became the prophet of signs. He was willing to do what God wanted, he just wouldn't talk. So God said, "Very well. Since you are willing, I will work with you in another way. Go out into the desert and I'll explain what I expect." Ezekiel couldn't utter one word, yet God chose him to be a prophet! God can use anyone whose heart is right.

**"So I [Ezekiel] got up and went out to the plain. And the glory of the Lord was standing there, like the glory I had seen by the Kebar River, and I fell facedown. Then the Spirit came into me and raised me to my feet. He spoke to me and said: 'Go, shut yourself inside your house. And you, son of man, they will tie with ropes; you will be bound so that you cannot go out among the people. I will make your tongue stick to the roof of your mouth so that you will be silent and unable to rebuke them, for they are a rebellious people. But when I speak to you, I will open your mouth and you shall say to them, "This is what the Sovereign Lord says." Whoever will listen let them listen, and whoever will refuse let them refuse [power of choice]; for they are a rebellious people.'**" (Ezekiel 3:23-27)

Ezekiel was simply a conduit by which God spoke. He wasn't angry with his kinsmen, it was the Lord who was angry. But the message he delivered made the people mad with him, not the Lord. This is why the life span of a prophet was very short. How would you like to have Ezekiel's responsibility on your shoulders? I want to meet Ezekiel one day and run up to him

and hug him. I don't expect him to say very much, but I want to tell him what a blessing he was with all the words he wrote.

\* \* \* \* \*

Ezekiel Chapter 4 is a prophecy seen from his perspective and pertains to a time seven years hence. **“Now, son of man, take a block of clay, put it in front of you and draw the city of Jerusalem on it. Then lay siege to it: Erect siege works against it, build a ramp up to it, set up camps against it and put battering rams around it. Then take an iron pan, place it as an iron wall between you and the city and turn your face toward it. It will be under siege, and you shall besiege it. This will be a sign to the people of Israel. Then lie on your left side and put the sin of the people of Israel upon yourself. You are to bear their sin for the number of days you lie on your side. I have assigned you the same number of days as the years of their sin. So for 390 days you will bear the sin of the people of Israel. After you have finished this, lie down again, this time on your right side, and bear the sin of the people of Judah. I have assigned you 40 days, a day for each year.”** (Ezekiel 4:1–6)

God was having Ezekiel pantomime what Nebuchadnezzar was going to do to Jerusalem. History shows that seven years later, Nebuchadnezzar spent eighteen months bringing Jerusalem to its knees.

The iron pan represents that God would not listen to prayers and pleas for help when the siege began. Ezekiel's lying down indicates Jerusalem was under siege because of the sin of its people. And that God would keep count of the years of apostasy: 390 for the northern ten tribes, and 40 for the southern two tribes—a day for a year.

Now, Ezekiel wasn't lying on his side all day long. Each day he would go into the middle of the city and lie on his side for a certain amount of time. The total number of days Ezekiel was going to lay on his left and right sides totals 430 days.

The amount of food he would eat each day was only about eight ounces, or one cup. I have eaten more food taste testing while cooking. This was a famine diet eaten at set times. And he only drank about three cups of water per day.

Evidently, the Lord supernaturally sustained Ezekiel in this because based on information from the Mayo Clinic, a man loses around 12 cups of water per day breathing, prospering, and through waste.

Notice the Lord wanted him to use human excrement as cooking fuel so the people would understand they would eat defiled food when taken prisoner. But this was just too much for Ezekiel and he pleaded with the Lord to not make him do it. The Lord relented and allowed him to use cow manure instead.

God was predicting famine upon Jerusalem, and the people were going to waste away because of it. At this time though, the people didn't know what was coming. They didn't understand the fate that awaited their city. They didn't comprehend what God was about to do. The total destruction of Jerusalem wouldn't occur for seven more years, in 586 bc.

Famine is one of God's four deadly judgments. He uses famine because it destroys effectively. In those days, an army would surround a city, lay siege to cut off its food and water supply, and then wait.

So Ezekiel, at the time of siesta, laid on his side for over a year! There is a lot more to this than meets the eye. To understand though, we have to know how God counts time.

Leviticus 25:1-5, **"The Lord said to Moses at Mount Sinai, 'Speak to the Israelites and say to them: "When you enter the land I am going to give you, the land itself must observe a sabbath to the Lord. For six years sow your fields, and for six years prune your vineyards and gather their crops. But in the seventh year the land is to have a year of sabbath rest, a sabbath to the Lord. Do not sow your fields or prune your vineyards. Do not reap what grows of itself or harvest the**

**grapes of your untended vines. The land is to have a year of rest.””**

People mistakenly believe this is the agricultural practice of land management. But that isn't the case. It has nothing to do with agriculture. If it were, the land would have declined in productivity year after year. The sixth year would have been the least productive, not the most productive. Then after the rest, the most abundant harvest would come the first year.

Yet that wasn't the case. God did the opposite. Leviticus 25 states that He made year six the most productive.

This was a test of faith. Will this agrarian people have faith in Him to provide for their needs?

See, in the wilderness, the land didn't need rest because they weren't planting. Instead the Lord provided manna every day except Sabbath. For forty years He demonstrated on the Sabbath that He could be trusted to provide. God uses the Sabbath to constantly test our relationship with Him.

When Jesus was on earth, Israel was still missing the entire point of the seventh day Sabbath. Its leaders even accused Jesus, the one who made the Sabbath, of breaking it.

The synchrony of time needs to be addressed. The counting of days began at creation. When we talk about the seventh day of the week, we are counting from the first day of the week. But what is the seventh year counted from? Notice in drawing 2.1, the Lord began a new calendar at the Exodus in 1437 bc.

In Exodus 12, **“The Lord said to Moses and Aaron in Egypt, ‘This month is to be for you the first month, the first month of your year.’”** (Exodus 12:1–2)

Today, we use a base-ten system for counting. A *decade* is ten years. But like the *week*, not just any ten years make a decade. A decade begins with a zero year and ends with the ninth year: 0–9 equals 10. Ten decades is a *century*.

In God's counting scheme, He doesn't use base ten for counting years, He uses base seven instead.

### Counting Years B.C.

Week	S	M	T	W	T	F	S
01	1437	36	35	34	33	32	31
02	1430	29	28	27	26	25	24
03	1423	22	21	20	19	18	17
04	1416	15	14	13	12	11	10
05	1409	08	07	06	05	04	03
06	1402	01	00	99	98	97	96

Drawing 2.1

### Counting years from Exodus

Week	S	M	T	W	T	F	S
01	1	2	3	4	5	6	7
02	8	9	10	11	12	13	14
03	15	16	17	18	19	20	21
04	22	23	24	25	26	27	28
05	29	30	31	32	33	34	35
06	36	37	38	39	40	41	42

Drawing 2.2

We see in drawing 2.2 how one *week* is seven days. But not just any seven days can be a week. A week begins on Sunday, the first day of the week and continues through Sabbath, the seventh day of the week. For example: Tuesday to Monday is seven days but not considered a week because a week always begins on a Sunday. In the same way, a week of years is seven years and always begins with a Sunday year. Seven weeks of years equal forty-nine years—a jubilee cycle.

God doesn't use decades and centuries, instead He uses weeks and jubilee cycles to measure time. The synchrony of the first Sabbath year always dates back to the Exodus in 1437 bc. Also notice in drawing 2.3, Israel's first full year in the Promised Land was a Sabbath year in 1396 BC. (Joshua 5) It is also interesting that Adam and Eve's first full day in the Garden of Eden was a Sabbath day, the seventh day of the week.

When Jesus comes, I believe He will return at the end of the Friday millennium, right on time. The saints' first full millennium in heaven will then be the Sabbath millennium of Revelation 20.

A century starts in a year that has two zeros and ends with one that has two nines. But like the other two measures of time, not just any one-hundred-year period can be a century.

Leviticus 25:8–12 says, **“Count off seven sabbath years—seven times seven years—so that the seven sabbath years amount to a period of forty-nine years. Then have the trumpet sounded everywhere on the tenth day of the seventh month; on the Day of Atonement sound the trumpet throughout your land. Consecrate the fiftieth year and proclaim liberty throughout the land to all its inhabitants. It shall be a jubilee for you; each of you is to return to your family property and to your own clan. The fiftieth year shall be a jubilee for you; do not sow and do not reap what grows of itself or harvest the untended vines. For it is a jubilee and is to be holy for you; eat only what is taken directly from the fields.”**

The Day of Atonement is the tenth day of the seventh month. God uses the juxtaposition of these two numbers quite often because they are significant. For example, both the dragon in Revelation 12 and the beast in Revelation 13 have seven heads and ten horns.

The Jubilee year was a year of freedom. All slaves were set free and all land was given back to its original owners. The land could never be sold. If a landowner fell on hard times, they could lease the land. However, in the fiftieth year (the first year after a forty-nine-year Jubilee cycle) the land returned to its original owner.

God did this to prevent some families from becoming too wealthy and others too poor. In God's economy, He has given enough wealth for everyone to partake. But some people are better at managing money; therefore, God planned that none of His children would stay in poverty.

The Feast of Pentecost, also known as the Feast of Weeks, was always celebrated on the fiftieth day. God told Israel to count off seven full weeks (forty-nine days) and on the fiftieth day, celebrate the feast. The fiftieth day always fell on Sunday, the first day of the week; yet it was the fiftieth day, inclusively, with the last forty-nine-day cycle. So the fiftieth day of the old cycle and the first day of the new cycle were the same day!

The Feast of Pentecost is a miniature of the Jubilee Year—they are identical—70 weeks are 490 years. This proves that the fiftieth year and the first year were the same year. If they weren't, the years would out of sync.

For example, if the fiftieth year is the last year and Monday is the first year, you have Sabbath being the sixth year of the next cycle. This won't work; the synchrony of the weekly cycle is gone.

God's Sabbaths are non-negotiable. Leviticus describes the penalty for ignoring God's commands. Leviticus 26:14–17, **“But if you will not listen to me and carry out all these**

**commands, and if you reject my decrees and abhor my laws and fail to carry out all my commands and so violate my covenant, then I will do this to you: I will bring on you sudden terror, wasting diseases and fever that will destroy your sight and sap your strength. You will plant seed in vain, because your enemies will eat it. I will set my face against you so that you will be defeated by your enemies; those who hate you will rule over you, and you will flee even when no one is pursuing you.”** God was promising destruction.

**Leviticus 26:31–35, “I will turn your cities into ruins and lay waste your sanctuaries, and I will take no delight in the pleasing aroma of your offerings. I myself will lay waste the land, so that your enemies who live there will be appalled. I will scatter you among the nations and will draw out my sword and pursue you. Your land will be laid waste, and your cities will lie in ruins. Then the land will enjoy its sabbath years all the time that it lies desolate and you are in the country of your enemies; then the land will rest and enjoy its sabbaths. All the time that it lies desolate, the land will have the rest it did not have during the sabbaths you lived in it.”**

Israel didn't understand the significance of this.

Drawing 2.3 shows that in one Jubilee cycle of forty-nine years, there are eight sabbatical years: seven Sabbath years (pink) and one Jubilee year (blue). God likes His children to be well-rested! Remember, Ezekiel had to lie on his side for four hundred and thirty days—a day for a year. Four hundred and thirty years contain exactly seventy Sabbath years.

In drawing 2.4, I've taken seven years and numbered the days across sequentially to make one week of years. Then, I've placed six more weeks below it, making a chart containing forty-nine years. In one Jubilee cycle, there are eight Sabbaths. The first year of the cycle and seven Sabbath years equal eight.

Eight Jubilee cycles are exactly three hundred and ninety-two years and contain sixty-four Sabbaths.



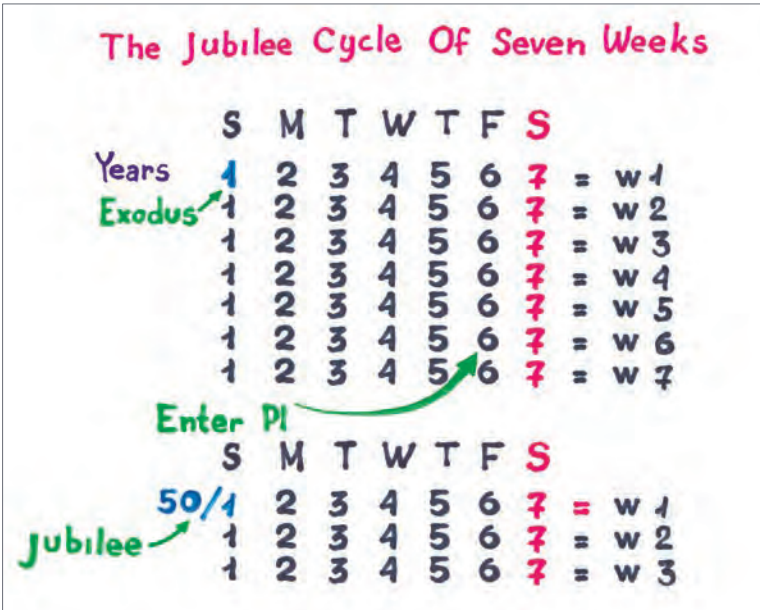

Drawing 2.3



Drawing 2.4

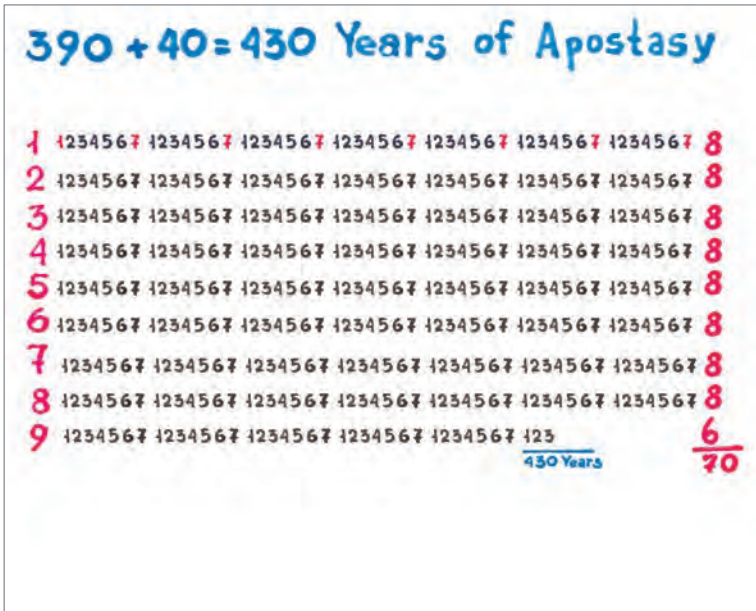

Drawing 2.5

The only Jubilee cycle that didn't contain eight Sabbath years was the very first one in 1437 bc. To reach four hundred and thirty years, we only use thirty-eight years of the next Jubilee cycle.

Notice how this works in drawing 2.5. In thirty-eight years, there are exactly six Sabbaths. Therefore the total number of Sabbaths in four hundred and thirty years is exactly seventy Sabbaths.

This explains two profound points:

(1) The reason that Babylonian captivity was seventy years is due to Israel and Judah having violated seventy Sabbath years. God's patience ran out. He desolated the land using Nebuchadnezzar so that the land could rest.

(2) God didn't do this to give the dirt rest. God was protecting His temple, the seventh-year sabbatical, and the holiness of seven. When Israel had violated seventy Sabbath years, God

said, “That’s it.” In 605 bc, a Sabbath year, the first siege of Jerusalem occurred. God wants His Sabbath kept. Yet, man prefers it out of sight.

2 Chronicles 36:20–21, **“He [Nebuchadnezzar] carried into exile to Babylon the remnant, who escaped from the sword, and they became servants to him and his successors until the kingdom of Persia came to power. The land enjoyed its sabbath rests; all the time of its desolation it rested, until the seventy years were completed in fulfillment of the word of the Lord spoken by Jeremiah.**

Chronicles summed it up so beautifully. The land received what it had been missing for so long.

\* \* \* \* \*

God came to Ezekiel with a specific message for a specific people at a specific time, and God wanted His message delivered. This is unlike the gospel commission God gives each born-again Christian. The responsibility of the Christian and the responsibility of the prophet are different. The difference is: To whom much is given, more is required.

God gave a direct message to the prophet Ezekiel. And I would suggest that if God speaks directly to you, do what He tells you! Until then, He gives us His word. Like a preacher, we should study and share; not only in word but by example. But be careful! It’s frustrating to hear people say, “God told me, or God said to me,” when in reality, He didn’t.

This reminds me of Jeremiah’s warning, **“‘Yes,’ declares the Lord, ‘I am against the prophets who wag their own tongues and yet declare, “The Lord declares.” Indeed, I am against those who prophesy false dreams,’ declares the Lord. ‘They tell them and lead my people astray with their reckless lies, yet I did not send or appoint them. They do not benefit these people in the least,’ declares the Lord.”** (Jeremiah 23:31–33)

At the onset, God did not intend to destroy Jerusalem in 586 bc. He would have relented and shown mercy had Israel been

willing to cooperate. God had three prophets admonishing Israel to repent and follow Him. He even had Nebuchadnezzar make three trips to subdue Israel. By the third siege, God completely destroyed the city. Nebuchadnezzar was the sword of the Lord.

In the story of Jonah, Nineveh was a parallel of this event. God sent Jonah to announce destruction upon the city if the Ninevites didn't repent. God relented from destroying Nineveh and would have spared Jerusalem had it repented.

\* \* \* \* \*

In 593 bc, God was having Ezekiel act out warnings which pertained to Jerusalem's destruction seven years hence.

**Ezekiel 5:1-4, "Now, son of man, take a sharp sword and use it as a barber's razor to shave your head and your beard. Then take a set of scales and divide up the hair. When the days of your siege come to an end, burn a third of the hair [on the clay tablet] inside the city. Take a third and strike it [chop it up into smaller pieces] with the sword all around the city. And scatter a third to the wind. For I will pursue them with drawn sword. But take a few hairs and tuck them away in the folds of your garment. Again, take a few of these and throw them into the fire and burn them up. A fire will spread from there to all Israel."** God would save a remnant, but the rest would be destroyed.

God chose to use hair to represent what He was going to do to His people. Shaving the head and beard was a sign of great distress. It reminds me of the text that God knows the number of hairs on our heads. (Matthew 10:30)

Notice the use of a third, third, third. God had divided the people into thirds. In ancient times, it was the customary rule of war for a king to destroy a rebellious city. If the king happened to be in a generous mood, he might have spared one-third of its inhabitants.

In 2 Samuel 8:2, **"David also defeated the Moabites. He**

**made them lie down on the ground and measured them off with a length of cord. Every two lengths of them were put to death, and the third length was allowed to live. So the Moabites became subject to David and brought him tribute.”**

The Moabites rejected the authority of David and would not pay taxes, so David sent the IRS to collect the tribute. When that didn't work, David sent soldiers. After defeating them, he made the survivors (men, women, and children) lie on the ground. After measuring them off with a length of cord, every two lengths was put to death, allowing one-third to live. Once this was done, the third allowed to live, bowed before the king's great mercy, and were pleased to pay the tax.

In ancient times, a generous king might spare one-third. During the first four trumpets of the great tribulation, two-thirds are spared. Such is the generosity, mercy, and grace of God. God told Ezekiel in verse 3, “Set aside a few hairs (a remnant). I'm going to work with part of this remnant to accomplish what I want done.”

**Ezekiel 5:5–7, “This is what the Sovereign Lord says: This is Jerusalem, which I have set in the center of the nations, with countries all around her. Yet in her wickedness she has rebelled against my laws and decrees more than the nations and countries around her. She has rejected my laws and has not followed my decrees. Therefore this is what the Sovereign Lord says: You have been more unruly than the nations around you and have not followed my decrees or kept my laws. You have not even conformed to the standards of the nations around you.”**

Jerusalem was set in the center of the nations to be a light to the Gentiles. The number one factor in buying valuable real estate is location, location, location! God chose this land because of its location. He gave it to Abraham's descendants, and yet, they had to be thrown out. And, because of their continued rebellion, God utterly decimated the land.

If we don't understand the Bible's use of language and

idioms, we will read the book of Ezekiel and make wrong conclusions. But, when we view it from his perspective, the Bible makes sense just as it reads. That's precisely how it should work. To make verses mean what they don't say is to distort the Bible. Israel's ethical and moral standards were so low, the surrounding heathen nations were shocked. God couldn't use the very people He had chosen to be closest to Him.

**“Therefore this is what the Sovereign Lord says: I myself am against you, Jerusalem, and I will inflict punishment on you in the sight of the nations. Because of all your detestable idols, I will do to you what I have never done before and will never do again. Therefore in your midst parents will eat their children, and children will eat their parents. [Food will be so scarce, they will eat one another.] I will inflict punishment on you and will scatter all your survivors to the winds. Therefore as surely as I live, declares the Sovereign Lord, because you have defiled my sanctuary with all your vile images and detestable practices, I myself will shave you; I will not look on you with pity or spare you. A third of your people will die of the plague or perish by famine inside you; a third will fall by the sword outside your walls; and a third I will scatter to the winds and pursue with drawn sword.”**  
(Ezekiel 5:8–12)

God said, **“I will inflict punishment on you.”** He takes full credit for being the source of Israel's punishment. In ad 70, Jerusalem was totally destroyed. Verse 9 is not referring to the destruction of Jerusalem per se, God is promising that He will never destroy Israel and REDEEM it again. This is a profound point! Many Christians believe that the Israel established in 1948 is a fulfillment of Old Testament prophecies. But the Bible doesn't teach that. It teaches that when Israel rejected and crucified Jesus, God *redefined* Israel.

Daniel 9 mentions seventy weeks because God wanted Israel to know that if they rejected Him again, He would move from *Plan A* to *Plan B*. God was giving them one final

opportunity to work with Him. History proves that to be the case. Paul makes clear that it is believers in Christ who are now the heirs of what was promised to Abraham, not his biological descendants. (Galatians 3:28–29)

God is describing why He had Ezekiel use the iron skillet in Chapter 4. The Old Testament describes how kings would place idols inside God's temple and worship them. It is difficult to comprehend how debasing and immoral Israel had become. And God would no longer tolerate their insults.

**Ezekiel 14:21, “For this is what the Sovereign Lord says: How much worse will it be when I send against Jerusalem my four dreadful judgments—sword and famine and wild beasts and plague—to kill its men and their animals!”**

We need to understand that God kills, because in Revelation 6:8, the fourth seal happens. This event is eminent.

**John writes, “I looked, and there before me was a pale horse! Its rider was named Death, and Hades was following close behind him. They were given power over a fourth of the earth to kill by sword, famine and plague, and by the wild beasts of the earth.”**

They were given power over twenty-five percent the earth. If eight billion people are on this earth, twenty-five percent is two billion. When the fourth seal is opened, God is going to annihilate earth because of degeneracy. This speaks volumes about the deplorable condition of people.

Many, then, didn't believe God would do this. Ezekiel was telling Israel that God indeed would, and it made them angry. They didn't want to believe it any more than Christians do today. But disbelief has nothing to do with reality.

**Ezekiel 5:13–17, “Then my anger will cease and my wrath against them will subside, and I will be avenged. And when I have spent my wrath on them, they will know that I the Lord have spoken in my zeal. I will make you a ruin and a reproach among the nations around you, in the sight of all who pass**

**by. You will be a reproach and a taunt, a warning and an object of horror to the nations around you when I inflict punishment on you in anger and in wrath and with stinging rebuke. I the Lord have spoken. When I shoot at you with my deadly and destructive arrows of famine, I will shoot to destroy you. I will bring more and more famine upon you and cut off your supply of food. I will send famine and wild beasts against you, and they will leave you childless. Plague and bloodshed will sweep through you, and I will bring the sword against you. I the Lord have spoken.”**

Verse 14 could be the primary source of anti-Semitism. God promised Israel that He would make them a reproach among the nations because of their apostasy. God was saying, “I will make people dislike you.” Now understand, I’m not saying this—God did! Read it again for yourself.

I am trying to be thorough because it’s important to understand how God deals with all people, not just Israel. God’s treatment of Israel is how He treats all nations. Ezekiel Chapter 6 will explain these judgments even more clearly.

Although the book of Ezekiel pertains to Israel between 593 and 586 bc, and because God is always consistent, there is a parallel during the end time.

In Revelation 7 and 8, the Lord will destroy the earth using the same four judgments He brought against Israel. And when the trumpets begin, two billion people will immediately die from sword, famine, plague, and wild beasts. Then in the sixth trumpet, another one-third of mankind will be destroyed.

The carnage is hard to conceptualize. The Lord is merciful, generous, and loving, but He is a terror to those in rebellion.

Today, we have an inaccurate caricature of God, just like Israel of old, because most people don’t study their Bibles. Israel made up what they wanted God to be and worshiped deities that didn’t exist; they rejected the God of heaven.

God repeatedly says through Ezekiel, “When I have done



these things, then they will know that I am the Lord.” This is the problem today: people don’t know the Lord.

Is your god the God of the Bible? Can He be understood from His past actions?

When I look at the flood, Sodom and Gomorrah, and Jerusalem, I have no doubt about what God is capable of doing. I know people reject the notion of God causing destruction, but that is not scriptural. They aren’t describing the God of heaven. If you think the God of the Old Testament is more destructive than the God of the New Testament, you haven’t read the book of Revelation.



## chapter 3



# Nobody Is Listening

In Chapter 5, God told Ezekiel what He was going to do to Israel. In Chapter 6, He justified His actions.

**Ezekiel 6:1–7, “The word of the Lord came to me: ‘Son of man, set your face against the mountains of Israel; prophesy against them and say: “You mountains of Israel, hear the word of the Sovereign Lord. This is what the Sovereign Lord says to the mountains and hills, to the ravines and valleys: I am about to bring a sword against you, and I will destroy your high places. Your altars will be demolished and your incense altars will be smashed; and I will slay your people in front of your idols. I will lay the dead bodies of the Israelites in front of their idols, and I will scatter your bones around your altars. Wherever you live, the towns will be laid waste and the high places demolished, so that your altars will be laid waste and devastated, your idols smashed and ruined, your incense altars broken down, and what you have made wiped out. Your people will fall slain among you, and you will know that I am the Lord.”’”**

The mountains are where the ancients believed God dwelled. Some people still do. *National Geographic* did a story in March 1992 on a group of Andean Indians who worship on sacred mountains. Visualize people offering incense on altars scattered around the mountains and you'll begin to understand God's disdain for this practice.

**Ezekiel 6:8–10, “But I will spare some, for some of you will escape the sword when you are scattered among the lands and nations. Then in the nations where they have been carried captive, those who escape will remember me—how I have been grieved by their adulterous hearts, which have turned away from me, and by their eyes, which have lusted after their idols. They will loathe themselves for the evil they have done and for all their detestable practices. And they will know that I am the Lord; I did not threaten in vain to bring this calamity on them.”**

God was saying, “I am going to destroy you but I will spare some.”

**Ezekiel 6:11–14, “This is what the Sovereign Lord says: ‘Strike your hands together and stamp your feet and cry out “Alas!” because of all the wicked and detestable practices of the people of Israel, for they will fall by the sword, famine and plague. One who is far away will die of the plague, and one who is near will fall by the sword, and anyone who survives and is spared will die of famine. So will I pour out my wrath on them. And they will know that I am the Lord, when their people lie slain among their idols around their altars, on every high hill and on all the mountaintops, under every spreading tree and every leafy oak—places where they offered fragrant incense to all their idols. And I will stretch out my hand against them and make the land a desolate waste from the desert to Diblah—wherever they live. Then they will know that I am the Lord.’”**

He said, “Don't be disgusted with my actions, be disgusted with your practices.” God kept saying, **“Then they will know**

**that I am the Lord.”**

He stresses this because they have forgotten. They don't know who He is. Do you see a parallel with the USA? Are you seeing the same transition into apostasy, darkness, and idolatry in our own country that ancient Israel practiced? If you can't, you are blind! You have eyes but can't see, and ears but can't hear.

I remember a news story here in the United States of how a celebrity had cut off her hair. Now, this happens every day at basic training and barber shops; Ezekiel even did it with a sword when God spoke to him. But for some strange reason, people find it news worthy when celebrities cut their hair. Yet, not one Christian in ten could explain why God told Ezekiel to do so.

The United States, just like all nations, is sliding down the slippery slope of decadence and degeneracy. There is great confusion about who the Lord is, and what He will do. There isn't one Christian church (that I have found) that believes (1) the fourth seal is the next to open, and (2) contains the seven trumpets which are punitive judgments of God.

Some churches believe the seven seals are in the future, but only after a rapture. There are some who believe the seven seals are in the past. The end result is the same. Neither have to worry. But when in the past did God kill twenty-five percent of earth's population because of rebellion and apostasy? Clearly, these two events haven't happened yet. However, they are coming!

Read Revelation 7. The 144,000 will come from the twelve tribes of Israel. Now, the twelve tribes of Israel aren't biological. The twelve tribes of biological Israel don't exist anymore. The 144,000 will come from a *redefined* Israel. God redefined it after Messiah was rejected. Now, all who are believers in Christ make up Israel.

James 1:1, **“James, a servant of God and of the Lord Jesus**

**Christ, To the twelve tribes scattered among the nations: Greetings.**” To whom is James writing? In James 2:1, He writes: **“My brothers and sisters, believers in our glorious Lord Jesus Christ.”** James calls the twelve tribes believers in Jesus Christ. And Peter concurs. **“But you are a chosen people, a royal priesthood, a holy nation, God’s special possession, that you may declare the praises of him who called you out of darkness into his wonderful light. Once you were not a people, but now you are the people of God; once you had not received mercy, but now you have received mercy.”** (1 Peter 2:9–10)

Ezekiel was sent as a messenger to Israel. He was to warn his own church and tell them that God was about to destroy the nation. Yet, God knew they were so rebellious they would only understand destruction. These weren’t heathen people. Of all people on earth, they should have known God.

A close friend once asked me, “Why was God silent during the time between the Old and New Testaments? There were no prophets talking during this time.” My answer was, “What else could He say? He sent seventeen prophets to Israel and Judah, and they ignored or killed them. Ezekiel warned they would have only one more chance. What else could He say to make them hear?” Furthermore, what else can He do for us here in the United States?

\* \* \* \* \*

In Ezekiel 7, God revealed His plans. And those who study His Word today can understand what He was and is about to do. What is coming will be a time of tribulation but also a time of great salvation.

Ezekiel 7:1–4, **“The word of the Lord came to me: ‘Son of man, this is what the Sovereign Lord says to the land of Israel: “The end! The end has come upon the four corners of the land! The end is now upon you, and I will unleash my anger against you. I will judge you according to your conduct and**

**repay you for all your detestable practices. I will not look on you with pity; I will not spare you. I will surely repay you for your conduct and for the detestable practices among you. Then you will know that I am the Lord.’’**”

The four corners are also mentioned in Revelation 7 where an angel stands at each corner of the earth. The four corners being north, south, east, and west. The Lord was saying, “I’ve run out of patience with you Israel. Now, I’m going to repay you for all of your detestable practices.” In Gods economy, restitution can never be escaped. Every debt is repaid.

When I watch television and see people conducting themselves immorally, doing what is an abomination to God, when I see people in corporate and political offices stealing, cheating, and lying, or when I hear about the murder and sexual immorality going on in our country, it tells me that God’s wrath is coming to our nation. He will repay us for our conduct and detestable practices, “Then we will know that He is the Lord.”

We’re just like Israel, we have numerous churches but believe everything is fine. We think we know God, but don’t believe His word. Christians go to church, sing about God, and get revved up emotionally, but where are those who study His word? Everyone claims they’re saved, but nobody is listening to His words.

Ezekiel 7:5–9, **“This is what the Sovereign Lord says: ‘Disaster! Unheard-of disaster! See, it comes! The end has come! The end has come! It has roused itself against you. See, it comes! Doom has come upon you, upon you who dwell in the land. The time has come! The day is near! There is panic, not joy, on the mountains. I am about to pour out my wrath on you and spend my anger against you. I will judge you according to your conduct and repay you for all your detestable practices. I will not look on you with pity; I will not spare you. I will repay you for your conduct and for the detestable practices among you. Then you will know that it is I the Lord who strikes you.’”**

God said over and over, **“I will not spare you.”** He wanted it burned into their memory. Repetition is a great teacher. When disaster struck, the wicked would be in the mountains—not having a praise service, not having a celebration—but hiding because of their sins. This was the grief that would have been experienced on the day of the Lord’s visitation in *Plan A*. The same doomsday will occur in *Plan B*.

Ezekiel 7:10, **“See, the day! See, it comes! Doom has burst forth, the rod has budded, arrogance has blossomed!”** Why is this important 2,600 years later? First, God is consistent and can be trusted—yesterday, today, and tomorrow. Second, God follows well defined policies when dealing with degenerate nations. If you understand what God did to Israel and why, the book of Revelation isn’t so mysterious.

Jeremiah 25:9 said, **“‘I will summon all the peoples of the north and my servant Nebuchadnezzar king of Babylon,’ declares the Lord, ‘and I will bring them against this land and its inhabitants and against all the surrounding nations. I will completely destroy them and make them an object of horror and scorn, and an everlasting ruin.’”**

He was going to bring destruction out of the north upon His own people using a king who didn’t even know Him. God sent the destroyer because of apostasy, a policy He consistently follows.

Jeremiah 25:5–7, **“They [His servants the prophets] said, ‘Turn now, each of you, from your evil ways and your evil practices, and you can stay in the land the Lord gave to you and your ancestors for ever and ever. Do not follow other gods to serve and worship them; do not arouse my anger with what your hands have made. Then I will not harm you. But you did not listen to me,’ declares the Lord, ‘and you have aroused my anger with what your hands have made, and you have brought harm to yourselves.’”**

The story in Daniel of when Belshazzar saw the writing on the wall is a parallel.



Daniel 5:18–23, “Your Majesty, the Most High God gave your father Nebuchadnezzar sovereignty and greatness and glory and splendor. Because of the high position he gave him, all the nations and peoples of every language dreaded and feared him. Those the king wanted to put to death, he put to death; those he wanted to spare, he spared; those he wanted to promote, he promoted; and those he wanted to humble, he humbled. But when his heart became arrogant and hardened with pride, he was deposed from his royal throne and stripped of his glory. He was driven away from people and given the mind of an animal; he lived with the wild donkeys and ate grass like the ox; and his body was drenched with the dew of heaven, until he acknowledged that the Most High God is sovereign over all kingdoms on earth and sets over them anyone he wishes. But you, Belshazzar, his son, have not humbled yourself, though you knew all this. Instead, you have set yourself up against the Lord of heaven. You had the goblets from his temple brought to you, and you and your nobles, your wives and your concubines drank wine from them. You praised the gods of silver and gold, of bronze, iron, wood and stone, which cannot see or hear or understand. But you did not honor the God who holds in his hand your life and all your ways.”

The reason Babylon would be destroyed is because of its evil ways.

About one hundred years earlier, Isaiah had said, “**This is what the Lord says to his anointed, to Cyrus, whose right hand I take hold of to subdue nations before him and to strip kings of their armor, to open doors before him so that gates will not be shut: I will go before you and will level the mountains; I will break down gates of bronze and cut through bars of iron.**” (Isaiah 45:1–2)

When God told Isaiah about the destruction of Babylon, Cyrus wasn’t even born yet. The Babylonian kingdom was made up of two kings: Cyrus the Persian and Darius the

Meade. Darius ultimately took authority over Babylon, but it was Cyrus who led the military conquest. He didn't subdue these nations through his own military prowess though, God did it for him. God empowered and enabled Cyrus to destroy Babylon—the most powerful nation on earth at that time.

Jeremiah 51:48–49, “**Then heaven and earth and all that is in them will shout for joy over Babylon, for out of the north destroyers will attack her,**’ declares the Lord. **‘Babylon must fall because of Israel’s slain, just as the slain in all the earth have fallen because of Babylon.’**”

Jeremiah was in Jerusalem at the time, Ezekiel and Daniel were in Babylon. The fall of Jerusalem should not be confused with the fall of Babylon. There are differences. This is important to understand because the prophecies of Ezekiel are not end time prophecies. Many mistakenly apply them to the end time, but they belong to ancient Israel.

In Revelation, there is textual support for some parallels found in Ezekiel. But applying them to any other time violates Scripture and logic. We have to understand this or become confused in our interpretation of prophecy.

The prophecies for ancient Israel and the prophecies for the end of the world can't be merged together. Ezekiel 9, 38, and 39, have nothing to do with the end of the world. They are unique to 586 bc.

Ezekiel 7:11–22, “**Violence has arisen, a rod to punish the wicked. None of the people will be left, none of that crowd—none of their wealth, nothing of value. The time has come! The day has arrived! Let not the buyer rejoice nor the seller grieve, for my wrath is on the whole crowd. The seller will not recover the property that was sold—as long as both buyer and seller live. For the vision concerning the whole crowd will not be reversed. Because of their sins, not one of them will preserve their life.**”

“**They have blown the trumpet, they have made all things**

ready, but no one will go into battle, for my wrath is on the whole crowd. Outside is the sword; inside are plague and famine. Those in the country will die by the sword; those in the city will be devoured by famine and plague. The fugitives who escape will flee to the mountains. Like doves of the valleys, they will all moan, each for their own sins. Every hand will go limp; every leg will be wet with urine. They will put on sackcloth and be clothed with terror. Every face will be covered with shame, and every head will be shaved.”

“They will throw their silver into the streets, and their gold will be treated as a thing unclean. Their silver and gold will not be able to deliver them in the day of the Lord’s wrath. [The most precious thing to the carnal heart is money. But] It will not satisfy their hunger or fill their stomachs, for it has caused them to stumble into sin. They took pride in their beautiful jewelry and used it to make their detestable idols. They made it into vile images; therefore I will make it a thing unclean for them. I will give their wealth as plunder to foreigners and as loot to the wicked of the earth, who will defile it. I will turn my face away from the people, and robbers will desecrate the place I treasure. They will enter it and will defile it.”

And this is exactly what Nebuchadnezzar did: he carried all of the plunder back to Babylon. These verses sound very much like Revelation 18.

Ezekiel 7:23–27, “**Prepare chains! For the land is full of bloodshed, and the city is full of violence. I will bring the most wicked of nations to take possession of their houses. I will put an end to the pride of the mighty, and their sanctuaries will be desecrated. When terror comes, they will seek peace in vain. Calamity upon calamity will come, and rumor upon rumor. They will go searching for a vision from the prophet, priestly instruction in the law will cease, the counsel of the elders will come to an end. The king will mourn, the prince will be clothed with despair, and the hands of the**

**people of the land will tremble. I will deal with them according to their conduct, and by their own standards I will judge them. Then they will know that I am the Lord.”**

Get the handcuffs ready, they’re going off to prison.

Terror is not unique to our age. Fear and anxiety have rested upon every nation. Perplexities and problems with no solutions, economic difficulties, and famine are signs of the times; signs that God’s wrath against our nation and the world are building. The sword (war) is coming.

Should we expect God to explain what He is about to do? He already has and no one is listening. Remember the iron skillet that Ezekiel held up to his face? Priest and pastors are so confused about what the Bible teaches today, they don’t know what to preach. They are dumbfounded. Morality has deteriorated to the degree that only when God sends His judgments upon mankind, **“Then they will know that I am the Lord.”**

In 593 bc, God is giving Ezekiel an understanding of (a) why He must destroy Jerusalem in 586 bc, (b) why He will save a remnant, and (c) why He is going to restore His people to their land in an attempt to achieve the objectives for which Israel was selected. They were to be a light unto the world—a witness to the Gentiles—an example of what serving and loving and living for God was about.

Remember, God had a purpose for Israel at one time, but now has no use for them.

Scholars today, take textual evidence in Ezekiel, lift it out of context, move it to the end of time, distort it, and make all sorts of erroneous conclusions. Yes, the prophecies of Gog and Magog, and the prophecy of the dry bones sound a lot like prophecies in Revelation, but Ezekiel’s promises and offers of restoration do not apply to the end of time. They *only* apply to post-Babylonian captivity.

Jump way ahead to Ezekiel 36:17–19, **“Son of man, when the people of Israel were living in their own land, they defiled it**

**by their conduct and their actions. Their conduct was like a woman's monthly uncleanness in my sight. So I poured out my wrath on them because they had shed blood in the land and because they had defiled it with their idols. I dispersed them among the nations, and they were scattered through the countries; I judged them according to their conduct and their actions."**

This was foretelling a time of freedom. But for now Ezekiel and Daniel are still in Babylon.

**Ezekiel 36:20–21, "And wherever they went among the nations they profaned my holy name, for it was said of them, 'These are the Lord's people, and yet they had to leave his land.' I had concern for my holy name, which the people of Israel profaned among the nations where they had gone."**

Notice the Lord's ridicule of Israel? "They profaned my name because the people who understood said, 'Wait a minute, these are the people that claim to serve the living God, and yet He has thrown them out of the land they claim He gave to them.'" The heathen didn't understand what God was doing to the Israelites.

**Ezekiel 36:22–24, "Therefore say to the Israelites, 'This is what the Sovereign Lord says: It is not for your sake, people of Israel, that I am going to do these things, but for the sake of my holy name, which you have profaned among the nations where you have gone. I will show the holiness of my great name, which has been profaned among the nations, the name you have profaned among them. Then the nations will know that I am the Lord, declares the Sovereign Lord, when I am proved holy through you before their eyes. For I will take you out of the nations; I will gather you from all the countries and bring you back into your own land.'"**

Verse 24 is used today as proof that God was going to reestablish Israel in 1948. See the problem? The text has nothing to do with 1948. The text has to do with the restoration of Israel following their Babylonian captivity. (Jeremiah 25)

After seventy years of captivity, God would, for the last time, restore them to their own land and give them one last chance to live up to their promise and covenant to be His people—to do what they had agreed to do. This is not about the end of the world. It is about the decree of Cyrus.

Ezekiel 36:25, **“I will sprinkle clean water on you, and you will be clean; I will cleanse you from all your impurities and from all your idols.”** This is sanctuary language.

On the Day of Atonement, the high priest sprinkled blood on the Ark of the Covenant, the Altar of Incense, and the Altar of Burnt Offering to remove the record of sin. The sanctuary was cleansed by this sprinkling of blood. The Lord is using a parallel that should have been understood—the cleansing of water that baptism symbolizes.

Ezekiel 36:26–27, **“I will give you a new heart and put a new spirit in you; I will remove from you your heart of stone and give you a heart of flesh. And I will put my Spirit in you and move you to follow my decrees and be careful to keep my laws.”**

That is what God wanted. Daniel 9 says that after the seventy weeks (490 years), God wanted them to have put an end to sin and brought in everlasting righteousness. The Spirit would not dwell in anyone who didn’t want it. He would not change a heart of stone to one of flesh if it wasn’t wanted. God does not force His will on anybody. That would be the equivalent of spiritual rape.

God’s statements are not to be understood as unilateral decrees, they are instead bilateral promises. “If you will be my people, I will be your God. I will give you a new heart and put a new spirit in you.”

History affirms Israel didn’t want it so it never came to pass. That is why Jerusalem was destroyed in ad 70. God then redefined the whole constituency of Israel so that now, today, God’s true Israel are believers in Christ.

Read the books of Ephesians and Galatians, they explain what I've just said. God's first plan for Israel didn't happen and that's why He put them in Babylonian captivity.

\* \* \* \* \*

Let's backup to Ezekiel 8 now. The setting is before the destruction of Jerusalem. God is taking Ezekiel on a virtual 800-mile trip from Babylon to the temple in Jerusalem. He is showing Ezekiel the despicable activities happening in the temple. The Jews in Babylon had a bad attitude toward God because He was punishing them. He had destroyed their land and their lives so they didn't feel kindly toward God.

Isn't it human nature to defend our actions? The carnal nature is offended when we're castigated for doing wrong. This reminds of how patient a parent must be when dealing with small children. When you have a little child and they've done something wrong and you're ready to take care of the problem, have you noticed how quickly children will make excuses for their wrongdoing?

We often come to the Lord with that same attitude, don't we? You have to work with children a little while to lead them into confession before you punish them because you want them to understand why they're being disciplined. Sin has a grip on all of us just like that.

God is showing this vision to Ezekiel so he can justify to the people in Babylon what He is about to do to Jerusalem. He also wanted Ezekiel to understand why a remnant would be spared. His actions reveal the only way to overcome the grip of false religion is total destruction.

Ezekiel 8:1, **"In the sixth year, in the sixth month on the fifth day, while I was sitting in my house and the elders of Judah were sitting before me, the hand of the Sovereign Lord came on me there."**

This took place around September 592 bc—one year closer to the destruction of Jerusalem. When he wasn't acting out

God's instructions, Ezekiel didn't leave home. The elders came to his house to hear what he had to say.

**Ezekiel 8:2–5, “I looked, and I saw a figure like that of a man. From what appeared to be his waist down he was like fire, and from there up his appearance was as bright as glowing metal. He stretched out what looked like a hand and took me by the hair of my head. The Spirit lifted me up between earth and heaven and in visions of God he took me to Jerusalem, to the entrance of the north gate of the inner court, where the idol that provokes to jealousy stood. And there before me was the glory of the God of Israel, as in the vision I had seen in the plain. Then he said to me, ‘Son of man, look toward the north.’ So I looked, and in the entrance north of the gate of the altar I saw this idol of jealousy.”**

Ezekiel is contrasting the glory of God sitting on His throne with this dumb idol. How do you compare the Glory of the Almighty to an idol?

**Ezekiel 8:6, “And he said to me, ‘Son of man, do you see what they are doing—the utterly detestable things the Israelites are doing here, things that will drive me far from my sanctuary? But you will see things that are even more detestable.’”** As if that were even possible.

**Ezekiel 8:7–15, “Then he brought me to the entrance to the [inner] court. I looked, and I saw a hole in the wall [of the temple]. He said to me, ‘Son of man, now dig into the wall.’ So I dug into the wall and saw a doorway there. And he said to me, ‘Go in and see the wicked and detestable things they are doing here.’ So I went in and looked, and I saw portrayed all over the walls all kinds of crawling things and unclean animals and all the idols of Israel. In front of them stood seventy elders of Israel, and Jaazaniah son of Shaphan was standing among them. Each had a censer in his hand, and a fragrant cloud of incense was rising. He said to me, ‘Son of man, have you seen what the elders of Israel are doing in the darkness, each at the shrine of his own idol? They**



say, “The Lord does not see us; the Lord has forsaken the land [so they’ve turned to idols].” ’ Again, he said, ‘You will see them doing things that are even more detestable [than this].’ Then he [the Lord] brought me to the entrance of the north gate of the house of the Lord, and I saw women sitting there, mourning the god Tammuz. He said to me, ‘Do you see this, son of man? You will see things that are even more detestable than this.’”

The ancients worshiped all kinds of gods and one was a bug: the Scarab Beetle. They would draw these insects and other objects on the walls and worship them. Tammuz was the god of crops and animals. This god had a long history of being a deity worshiped by ancient nations of the Middle East. Tammuz-and-Ishtar was a Romeo-and-Juliet type of story, but it was their way of explaining life. The Lord was showing Ezekiel how corrupt Israel had become.

Ezekiel 8:16–18, “He then brought me into the inner court of the house of the Lord, and there at the entrance to the temple, between the portico and the altar, were about twenty-five men. With their backs toward the temple of the Lord and their faces toward the east, they were bowing down to the sun in the east. He said to me, ‘Have you seen this, son of man? Is it a trivial matter for the people of Judah to do the detestable things they are doing here? Must they also fill the land with violence and continually arouse my anger? Look at them putting the branch to their nose! Therefore I will deal with them in anger; I will not look on them with pity or spare them. Although they shout in my ears, I will not listen to them.’”

This was the height of insult. These twenty-five men were worshipping the sun, standing between the Altar and the Laver with their backs toward the Temple, the dwelling place of God. You never enter into the presence of almighty God with your back to Him. These men were worshipping the sun god in God’s Temple.

In Chapter 8, God showed Ezekiel that the hearts of Israel's leaders were hard. He also showed Ezekiel that He was going to reseed the nation of Israel and wanted to empower them through the Spirit to fulfill His purposes.

\* \* \* \* \*

Ezekiel 9:1–2, **“Then I heard him call out in a loud voice, ‘Bring near those who are appointed to execute judgment on the city, each with a weapon in his hand.’ And I saw six men coming from the direction of the upper gate, which faces north, each with a deadly weapon in his hand. With them was a man clothed in linen who had a writing kit at his side. They came in and stood beside the bronze altar.”** These seven men were standing beside the Altar of Burnt Offering.

Ezekiel 9:3–4, **“Now the glory of the God of Israel went up from above the cherubim, where it had been, and moved to the threshold of the temple. Then the Lord called to the man clothed in linen who had the writing kit at his side and said to him, ‘Go throughout the city of Jerusalem and put a mark on the foreheads of those who grieve and lament over all the detestable things that are done in it.’”** These seven men standing in the courtyard beside the bronze altar were being summoned by God to do a job. In this vision, the glory that was above the cherubim had moved to the threshold of the temple. The man in linen represents a clean priest, contrasted with the dirty ones previously mentioned.

In Jerusalem, Jeremiah was a faithful prophet of the Lord, but only one against hundreds of false prophets there. God was searching, qualifying the people who still loved and obeyed Him, and He wanted them separated from the others.

Ezekiel 9:5–6, **“As I listened, he said to the others, ‘Follow him through the city and kill, without showing pity or compassion. Slaughter the old men, the young men and women, the mothers and children, but do not touch anyone who has the mark. Begin at my sanctuary [the temple].’ So they began**

**with the old men who were in front of the temple.”**

The six men were to follow the one with the writing kit throughout the city and kill those without the mark. Notice that judgment begins at the temple (church). He says, “Start with the preachers, teachers, and priests.”

**Ezekiel 9:7–8, “Then he said to them, ‘Defile the temple and fill the courts with the slain. Go!’ So they went out and began killing throughout the city. While they were killing and I was left alone, I fell facedown, crying out, ‘Alas, Sovereign Lord! Are you going to destroy the entire remnant of Israel in this outpouring of your wrath on Jerusalem?’”**

God does not spare preachers or teachers or anyone from engaging in idolatry. This vision showed Ezekiel how He separated the one-third that would be spared. This man in linen isn’t literally going through Jerusalem putting an X on foreheads. This is a representation of how God separates people. God was showing Ezekiel that He was going to destroy those who were in apostasy and doing wrong.

Revelation 11 has a parallel for this type of action. When Ezekiel saw the destruction God issued for Jerusalem, he was blown away. Remember, this was six years before the destruction. Ezekiel just could not believe his kinsmen were so degenerate. He was stunned!

**Ezekiel 9:9–10:2, “He answered me, ‘The sin of the people of Israel and Judah is exceedingly great; the land is full of bloodshed and the city is full of injustice. They say, “The Lord has forsaken the land; the Lord does not see.” So I will not look on them with pity or spare them, but I will bring down on their own heads what they have done.’ Then the man in linen with the writing kit at his side brought back word, saying, ‘I have done as you commanded.’ I looked, and I saw the likeness of a throne of lapis lazuli above the vault that was over the heads of the cherubim. The Lord said to the man clothed in linen, ‘Go in among the wheels beneath the cherubim. Fill your hands with burning coals from**

**among the cherubim and scatter them over the city? And as I watched, he went in.”**

This is a parallel of what Ezekiel described in the first chapters of his book. He again saw God on the great glass expanse, and now, coals are going to be scattered over the city. This represented that God would pour out the Spirit on those He had marked and would spare as a remnant. Remember how tongues of fire appeared over the heads of those present at Pentecost? The remainder of Ezekiel Chapters 9 and 10 reiterated what has already been described; let's go to Ezekiel 11:15 and resume.

Ezekiel 11:15, **“Son of man, the people of Jerusalem have said of your fellow exiles and all the other Israelites, ‘They are far away from the Lord; this land was given to us as our possession.’”** They felt those who deserved punishment, God had already punished by sending them as captives to Babylon.

Their thinking was that God wasn't going to hurt Jerusalem anymore. The false prophets were preaching peace and safety when there was none. These erroneous prophesiers didn't believe God would punish them anymore, misleading the people.

Ezekiel 11:16, **“Therefore say: ‘This is what the Sovereign Lord says: Although I sent them far away among the nations and scattered them among the countries, yet for a little while I have been a sanctuary for them in the countries where they have gone.’”**

God was saying, “Yes, I scattered some of my people into captivity, but I have been their sanctuary where they are.”

Ezekiel 11:17, **“Therefore say: ‘This is what the Sovereign Lord says: I will gather you from the nations and bring you back from the countries where you have been scattered, and I will give you back the land of Israel again.’”**

He was saying, “That's right Ezekiel. These are your brothers. The land was given to Israel, yet they are still in captivity because of degeneracy. Go tell the elders in Babylon what I

have said: ‘I spanked you when you needed it, but you weren’t completely destroyed. I haven’t given up on you yet. I still have a plan.’”

You have to remember Ezekiel 36 here: context, context, context. This has nothing to do with Israel’s establishment as a nation in 1948. This has to do with it being reestablished after Babylonian captivity. Evangelical Christians have lifted these words out of their context and moved them to the end of time to create a whole new meaning. And good-hearted Christians buy into this foolishness because they never study their Bible. They listen to a sermon and believe what the preacher says without verifying if what he said is true. I just described the precise problem Israel was having: following their leaders who were leading them into idolatry. But neither the Israelites during Ezekiel’s day nor many Christians today know or follow God.

**Ezekiel 11:18–20, “They will return to it and remove all its vile images and detestable idols. I will give them an undivided heart and put a new spirit in them; I will remove from them their heart of stone and give them a heart of flesh. Then they will follow my decrees and be careful to keep my laws. They will be my people, and I will be their God.”**

This was going to happen by sprinkling coals of fire from the wheels of the four living creatures. The carnal heart cannot regenerate itself into being born again. It is a miracle that only God can and will do, if we submit ourselves totally to His will. We can only submit. That is all we can do. God has to do the rest.

Look at verse 19 again. God said to Ezekiel, “I know your kinsmen are in Babylon because of rebellion. I know your city is being destroyed because of their apostasy. They wouldn’t listen and submit to the Spirit; they wouldn’t keep my laws; they wouldn’t allow the Spirit to live within. That is why you are where you are. But I am going to spare those who grieve at the degeneracy—these are the ones who most likely will recover

from this great disaster. And IF they will respond to me, they will be my people and I will be their God.” What a marvelous promise. God wants us to follow Him. We need to be like Him. This demonstrates our love.

A bilateral covenant is a mutual agreement between two parties. Marriage is holy dead-lock if only one party loves the other. You take vows of fidelity because of love. In the same way, God says, “If my people will love me, if they will open up their hearts and let the Spirit in, I will be their God.”

**Ezekiel 11:21, “But as for those whose hearts are devoted to their vile images and detestable idols, I will bring down on their own heads what they have done, declares the Sovereign Lord.”**

Those living in Jerusalem are going to receive my wrath too. According to Ezekiel 9, the vision does not pertain to any other people than those to whom the vision was given. It only applies to those living in Jerusalem during the siege of 586 bc and then scattered to foreign lands.

People apply Ezekiel’s prophecies to the end of time but that is nonsense. To whom does Chapter 11 refer if not those in Chapter 9 who are scattered? You must stay within the context of the vision to clearly understand it.

**Ezekiel 11:22–25, “Then the cherubim, with the wheels beside them, spread their wings, and the glory of the God of Israel was above them. The glory of the Lord went up from within the city and stopped above the mountain east of it. The Spirit lifted me up and brought me to the exiles in Babylonia[a] in the vision given by the Spirit of God. Then the vision I had seen went up from me, and I told the exiles everything the Lord had shown me.”**

Ezekiel told the elders what the Lord had shown him. God was promising to pour out the Spirit. This happened at Pentecost after they rejected Jesus. When Jesus ascended, the final call went out to Israel to receive the Lord and fulfill His

purpose for which they had been called. Once they stoned Stephen in ad 33, the gospel was transferred to the Christians to share with the world. God was finally finished with the nation of Israel.

This vision puzzles many, but the meaning is quite simple. It demonstrates how God conducts judgment. God sees everything. The eyes of the Lord are upon us. He reads our hearts and knows our deeds. The Lord saw Israel then and He sees us today. His eyesight doesn't change. The land is still full of immorality and injustice. People think the Lord does not see, but He does. And He will bring down what we deserve on our heads for what we have done. He will see that whatever we have done to others will be done to us. He did it to Israel and He will do it to us.

Ezekiel's vision parallels the judgment of the living during the great tribulation. This vision is before the third and final destruction of Jerusalem. Ezekiel was shown that the Lord was going to spare the righteous but destroy the wicked. Those who grieved over their sins received the mark and were saved; all others were destroyed.

This is a parallel of the great tribulation. The details change a little, but the principle is the same. The man in linen represents Jesus who will examine every person. Those who grieve their sins and overcome through faith will receive God's seal. All others will be marked for destruction. During the great tribulation, the wicked will receive a physical mark—the mark of the beast. These people will be destroyed at the second coming.

In Ezekiel's vision, those marked were saved. In John's vision, those marked will be destroyed. It is the opposite, but the parallel is the same.





## chapter 4



# Zedekiah The Weasel

Let's return to Jeremiah briefly for a few comments. Chapters 38 and 39 tell a story. Jeremiah was in the city of Jerusalem, prophesying to King Zedekiah the word of the Lord that everyone in Jerusalem should surrender to Nebuchadnezzar.

Two sieges had already occurred, but since Israel's rebellion continued, God would send a final siege to totally destroy the city. When some men heard Jeremiah's message, they considered it treasonous and threw him in a pit to die. However a Cushite, someone who wasn't even a Jew, rescued him.

Jeremiah eventually gave the king the Lord's message. But the king, afraid of the people he had mistreated, refused to obey. When Nebuchadnezzar came and surrounded the city, after eighteen months the food ran out. Zedekiah snuck away but was captured and taken to Nebuchadnezzar. All of Zedekiah's officials were slaughtered before his eyes. Then, forced to look at Nebuchadnezzar, his own eyes were gouged out, after which he was led to Babylon to die.

We must understand the setting Ezekiel and Jeremiah are speaking from. My biggest pet peeve is seeing Scripture taken out of context. When our words are taken out of context and used inappropriately, we feel violated. The same disregard applies to the Bible.

At the time Jeremiah was talking to Zedekiah, Ezekiel was talking to the exiles in Babylon. This takes place just before the destruction of Jerusalem.

**Jeremiah 38:2–10, “This is what the Lord says: ‘Whoever stays in this city will die by the sword, famine or plague, but whoever goes over to the Babylonians will live. They will escape with their lives; they will live.’ And this is what the Lord says: ‘This city will certainly be given into the hands of the army of the king of Babylon, who will capture it.’ Then the officials said to the king, ‘This man should be put to death. He is discouraging the soldiers who are left in this city, as well as all the people, by the things he is saying to them. This man is not seeking the good of these people but their ruin.’ ‘He is in your hands,’ King Zedekiah answered. ‘The king can do nothing to oppose you.’ So they took Jeremiah and put him into the cistern of Malkijah, the king’s son, which was in the courtyard of the guard. They lowered Jeremiah by ropes into the cistern; it had no water in it, only mud, and Jeremiah sank down into the mud. But Ebed-Melek, a Cushite, an official in the royal palace, heard that they had put Jeremiah into the cistern. While the king was sitting in the Benjamin Gate, Ebed-Melek went out of the palace and said to him, ‘My lord the king, these men have acted wickedly in all they have done to Jeremiah the prophet. They have thrown him into a cistern, where he will starve to death when there is no longer any bread in the city.’ Then the king commanded Ebed-Melek the Cushite, ‘Take thirty men from here with you and lift Jeremiah the prophet out of the cistern before he dies.’”**

Jeremiah is in Jerusalem. Nebuchadnezzar is coming.

Jeremiah is telling the people what the Lord is doing. Zedekiah, a real wimp, didn't have the courage to obey the Lord.

**Jeremiah 38:11–13, “So Ebed-Melek took the men with him and went to a room under the treasury in the palace. He took some old rags and worn-out clothes from there and let them down with ropes to Jeremiah in the cistern. Ebed-Melek the Cushite said to Jeremiah, ‘Put these old rags and worn-out clothes under your arms to pad the ropes.’ Jeremiah did so, and they pulled him up with the ropes and lifted him out of the cistern. And Jeremiah remained in the courtyard of the guard.”**

Wasn't that a kind deed? He even thought to bring padding for the rope so they wouldn't hurt Jeremiah while pulling him out.

**Jeremiah 38:14–28, “Then King Zedekiah sent for Jeremiah the prophet and had him brought to the third entrance to the temple of the Lord. ‘I am going to ask you something,’ the king said to Jeremiah. ‘Do not hide anything from me.’ Jeremiah said to [the weasel] Zedekiah, ‘If I give you an answer, will you not kill me? Even if I did give you counsel, you would not listen to me.’**

**But King Zedekiah swore this oath secretly to Jeremiah: ‘As surely as the Lord lives, who has given us breath, I will neither kill you nor hand you over to those who want to kill you.’ Then Jeremiah said to Zedekiah, ‘This is what the Lord God Almighty, the God of Israel, says: “If you surrender to the officers of the king of Babylon, your life will be spared and this city will not be burned down; you and your family will live. But if you will not surrender to the officers of the king of Babylon, this city will be given into the hands of the Babylonians and they will burn it down; you yourself will not escape from them.”’”**

King Zedekiah said to Jeremiah, ‘I am afraid of the Jews who have gone over to the Babylonians, for the Babylonians may hand me over to them and they will mistreat me.’ ‘They

will not hand you over,' Jeremiah replied. 'Obey the Lord by doing what I tell you. Then it will go well with you, and your life will be spared. But if you refuse to surrender, this is what the Lord has revealed to me: All the women left in the palace of the king of Judah will be brought out to the officials of the king of Babylon. Those women will say to you:

**"They misled you and overcame you—those trusted friends of yours. Your feet are sunk in the mud; your friends have deserted you." All your wives and children will be brought out to the Babylonians. You yourself will not escape from their hands but will be captured by the king of Babylon; and this city will be burned down.'**

Then Zedekiah said to Jeremiah, 'Do not let anyone know about this conversation, or you may die. If the officials hear that I talked with you, and they come to you and say, "Tell us what you said to the king and what the king said to you; do not hide it from us or we will kill you," then tell them, "I was pleading with the king not to send me back to Jonathan's house to die there.'"

**All the officials did come to Jeremiah and question him, and he told them everything the king had ordered him to say. So they said no more to him, for no one had heard his conversation with the king. And Jeremiah remained in the courtyard of the guard until the day Jerusalem was captured."**

Notice what Jeremiah said. "If I told you the truth, you would kill me." The king's oaths were meaningless. Nebuchadnezzar was attacking Jerusalem because of Zedekiah. He is the ultimate politician: no principles, no gut, and no fidelity. Jeremiah told him what to do to be spared, but the king didn't heed the advice. He was more afraid of his own people.

Jeremiah 39:1–18, **"In January of the ninth year of King Zedekiah's reign, King Nebuchadnezzar of Babylon came with his entire army to besiege Jerusalem. Two and a half years later, on July 18 in the eleventh year of Zedekiah's reign, a section of the city wall was broken down. All the**

officers of the Babylonian army came in and sat in triumph at the Middle Gate: Nergal-sharezer of Samgar, and Nebo-sarsekim, a chief officer, and Nergal-sharezer, the king's adviser, and all the other officers of the king of Babylon.

When King Zedekiah of Judah and all the soldiers saw that the Babylonians had broken into the city, they fled. They waited for nightfall and then slipped through the gate between the two walls behind the king's garden and headed toward the Jordan Valley.

But the Babylonian troops chased them and overtook Zedekiah on the plains of Jericho. They captured him and took him to King Nebuchadnezzar of Babylon, who was at Riblah in the land of Hamath. There the king of Babylon pronounced judgment upon Zedekiah. The king of Babylon made Zedekiah watch as he slaughtered his sons at Riblah. The king of Babylon also slaughtered all the nobles of Judah. Then he gouged out Zedekiah's eyes and bound him in bronze chains to lead him away to Babylon."

Meanwhile, the Babylonians burned Jerusalem, including the royal palace and the houses of the people, and they tore down the walls of the city. Then Nebuzaradan, the captain of the guard, took as exiles to Babylon the rest of the people who remained in the city, those who had defected to him, and everyone else who remained. But Nebuzaradan allowed some of the poorest people to stay behind in the land of Judah, and he assigned them to care for the vineyards and fields.

King Nebuchadnezzar had told Nebuzaradan, the captain of the guard, to find Jeremiah. 'See that he isn't hurt,' he said. 'Look after him well, and give him anything he wants.' So Nebuzaradan, the captain of the guard; Nebushazban, a chief officer; Nergal-sharezer, the king's adviser; and the other officers of Babylon's king sent messengers to bring Jeremiah out of the prison. They put him under the care of Gedaliah son of Ahikam and grandson of Shaphan, who took him back to his home. So Jeremiah stayed in Judah among his own people.

**“The Lord had given the following message to Jeremiah while he was still in prison: ‘Say to Ebed-melech the Ethiopian, “This is what the Lord of Heaven’s Armies, the God of Israel, says: I will do to this city everything I have threatened. I will send disaster, not prosperity. You will see its destruction, but I will rescue you from those you fear so much. Because you trusted me, I will give you your life as a reward. I will rescue you and keep you safe. I, the Lord, have spoken!”’” (Jeremiah 39:1–18 NLT)**

This final siege took eighteen months. But what happened to Jeremiah and the king? Jeremiah lived and the king died. I’ve included this detail because in Ezekiel 12, we find that before all of these things happened, Ezekiel would act out this whole drama before it came to pass. We have to understand what is going on with the weasel, Zedekiah, to really appreciate what Ezekiel saw six years earlier.

If people would only take the time to read their Bibles, these stories would become more exciting than ever before. It is amazing to see how the stories come together and how the Bible explains itself. It is truly the most relevant book in the entire world. It is the greatest selling book of all time and yet read by so very few.

\* \* \* \* \*

This was taking place around 595 bc, about ten years prior to the ultimate and final destruction of Jerusalem by Nebuchadnezzar. God predicted how King Zedekiah would attempt to run for his life by escaping through a hole in the wall. It was actually a small gate, but God had Ezekiel dig a hole in the wall and climb through it while the elders were watching.

Jeremiah 38 records Zedekiah’s attempted escape and capture by Nebuchadnezzar. His sons were killed before his eyes; the last thing Zedekiah saw was the face of his captor as his eyes were gouged out.

Ezekiel 12 contains a prophecy that concerns Israel and

Zedekiah. The actual destruction to which this prophecy points happened in 586 bc. The whole focus of its words is local. It concerns God's people then, not modern Israel today. This prophecy happened long ago. It is critical to understand this. The prophecy of Ezekiel 12 was a local prophecy about Zedekiah that was fulfilled about 4 years after the vision was given.

**Ezekiel 12:1–2, “The word of the Lord came to me: ‘Son of man, you are living among a rebellious people. They have eyes to see but do not see and ears to hear but do not hear, for they are a rebellious people.’”**

They don't hear because they are rebellious. Do you see a parallel with today?

**Ezekiel 12:3–6, “Therefore, son of man, pack your belongings for exile and in the daytime, as they watch, set out and go from where you are to another place. Perhaps they will understand, though they are a rebellious people. During the daytime, while they watch, bring out your belongings packed for exile. Then in the evening, while they are watching, go out like those who go into exile. While they watch, dig through the wall and take your belongings out through it. Put them on your shoulder as they are watching and carry them out at dusk. Cover your face so that you cannot see the land, for I have made you a sign to the Israelites.”**

Ezekiel was to act this out while they watched. You can't argue with a pantomime because no one is talking. They know he is a prophet, they know God is saying something through him, so they just sit and watch, trying and figure out the message. This pantomime pertains to Jerusalem's coming destruction.

**Ezekiel 12:7–11, “So I did as I was commanded. During the day I brought out my things packed for exile. Then in the evening I dug through the wall with my hands. I took my belongings out at dusk, carrying them on my shoulders while they watched. In the morning the word of the Lord came to me: ‘Son of man, did not the Israelites, that rebellious**

people, ask you, “What are you doing?” Say to them, “This is what the Sovereign Lord says: This prophecy concerns the prince in Jerusalem and all the Israelites who are there.” Say to them, “I am a sign to you.” As I have done, so it will be done to them. They will go into exile as captives.’”

The prince in Jerusalem is Zedekiah. Jerusalem is going to be destroyed.

**Ezekiel 12:12–16, “The prince among them will put his things on his shoulder at dusk and leave, and a hole will be dug in the wall for him to go through. He will cover his face so that he cannot see the land. I will spread my net for him, and he will be caught in my snare; I will bring him to Babylonia, the land of the Chaldeans, but he will not see it, and there he will die. I will scatter to the winds all those around him—his staff and all his troops—and I will pursue them with drawn sword. They will know that I am the Lord, when I disperse them among the nations and scatter them through the countries. But I will spare a few of them from the sword, famine and plague, so that in the nations where they go they may acknowledge all their detestable practices. Then they will know that I am the Lord.”**

And this is exactly what happened. Zedekiah didn't see it because his eyes were plucked out. The sign is fulfilled in Jeremiah 38 and 39 to the letter—we just read about it. Israel knew why they were going to a foreign land. It wasn't because Nebuchadnezzar was a superior king. They understood they were paying the price for their detestable practices. Read Daniel's prayer in Daniel 9. There was no doubt why the Jews were in Babylonian captivity. God wants the world to know: A nation perishes when He removes His protection. This is happening to the United States even as I write this.

**Ezekiel 12:18–28, “Son of man, tremble as you eat your food. Shake with fear as you drink your water. Tell the people, “This is what the Sovereign Lord says concerning those living in Israel and Jerusalem: They will eat their food with**



trembling and sip their water in despair, for their land will be stripped bare because of their violence. The cities will be destroyed and the farmland made desolate. Then you will know that I am the Lord.’

Again a message came to me from the Lord: ‘Son of man, you’ve heard that proverb they quote in Israel: “Time passes, and prophecies come to nothing.” Tell the people, “This is what the Sovereign Lord says: I will put an end to this proverb, and you will soon stop quoting it.” Now give them this new proverb to replace the old one: “The time has come for every prophecy to be fulfilled!”’

There will be no more false visions and flattering predictions in Israel. For I am the Lord! If I say it, it will happen. There will be no more delays, you rebels of Israel. I will fulfill my threat of destruction in your own lifetime. I, the Sovereign Lord, have spoken!’

Then this message came to me from the Lord: ‘Son of man, the people of Israel are saying, “He’s talking about the distant future. His visions won’t come true for a long, long time.” Therefore, tell them, “This is what the Sovereign Lord says: No more delay! I will now do everything I have threatened. I, the Sovereign Lord, have spoken!”’” (NLT)

\* \* \* \* \*

Ezekiel 13:1–3, “The word of the Lord came to me: ‘Son of man, prophesy against the prophets of Israel who are now prophesying. Say to those who prophesy out of their own imagination: “Hear the word of the Lord! This is what the Sovereign Lord says: Woe to the foolish prophets who follow their own spirit and have seen nothing!”’”

God said something here that should make every Christian think twice. I hear a lot of people claim that “The Lord told me to do this, or the Lord told me to do that.” After looking at Ezekiel 13, I hope everyone who uses this kind of language will stop and thoughtfully consider their comments. The Lord

becomes very angry when people claim that He has spoken to them, when in fact He has not. Let's go back to Jeremiah's day for a moment before we proceed with Ezekiel 13 further.

Jeremiah is in Jerusalem, Ezekiel and Daniel are in Babylon—three prophets alive and speaking at the same time. Jeremiah and Ezekiel's stories especially merge because their prophecies concern what God had planned for Israel in *Plan A*. I'll discuss more about Daniel and *Plan B* later.

Jeremiah 25:8–9, **“Therefore the Lord Almighty says this: ‘Because you have not listened to my words, I will summon all the peoples of the north and my servant Nebuchadnezzar king of Babylon,’ declares the Lord, ‘and I will bring them against this land and its inhabitants and against all the surrounding nations. I will completely destroy them and make them an object of horror and scorn, and an everlasting ruin.’”**

God is going to send Nebuchadnezzar as a destroyer upon Israel and the surrounding nations because of rebellion.

Jeremiah 25:10–13, **“I will banish from them the sounds of joy and gladness, the voices of bride and bridegroom, the sound of millstones and the light of the lamp. This whole country will become a desolate wasteland, and these nations will serve the king of Babylon seventy years. But when the seventy years are fulfilled, I will punish the king of Babylon and his nation, the land of the Babylonians, for their guilt,’ declares the Lord, ‘and will make it desolate forever. I will bring on that land all the things I have spoken against it, all that are written in this book and prophesied by Jeremiah against all the nations.’”**

Daniel makes reference to this prophecy in Daniel 9.

Now, jump to Jeremiah 26:8–11, **“But as soon as Jeremiah finished telling all the people everything the Lord had commanded him to say, the priests, the prophets and all the people seized him and said, ‘You must die! Why do you**

prophecy in the Lord's name that this house will be like Shiloh and this city will be desolate and deserted?' And all the people crowded around Jeremiah in the house of the Lord. When the officials of Judah heard about these things, they went up from the royal palace to the house of the Lord and took their places at the entrance of the New Gate of the Lord's house. Then the priests and the prophets said to the officials and all the people, 'This man should be sentenced to death because he has prophesied against this city. You have heard it with your own ears!'"

Why were they so angry with Jeremiah? They were ready to condemn Jeremiah to death because He had foretold that what they regarded as holy would be destroyed. Shiloh was where the original tabernacle stood; it was eventually destroyed by Shalmaneser in 722 bc after Israel's split into two nations.

I remember a book written several years ago titled *The Satanic Verses* which was offensive to the Muslim community. They put a death decree on the head of its author. He was eventually attacked and lost an eye. It is considered blasphemy to profane Mohammed and anyone who does so is to be killed.

Well, the Jewish position in Jeremiah's day was the same; it was just a different holy object. Jeremiah was predicting Jerusalem's destruction and it made the people furious. They were ready to kill him.

Lest you think this phenomenon belongs only to others, consider yourself. If someone told you that your church and what goes on there is an abomination to God, how would you react? I can tell you—I've seen it. People will not listen. They get offended and become angry.

Jeremiah 26:12–15, **"Then Jeremiah said to all the officials and all the people: 'The Lord sent me to prophesy against this house and this city all the things you have heard. Now reform your ways and your actions and obey the Lord your God. Then the Lord will relent and not bring the disaster he has pronounced against you. As for me, I am in your**

**hands; do with me whatever you think is good and right. Be assured, however, that if you put me to death, you will bring the guilt of innocent blood on yourselves and on this city and on those who live in it, for in truth the Lord has sent me to you to speak all these words in your hearing.”**

Jeremiah said, “Look, the Lord sent me to prophesy against this city, now repent! Do what you want with me, but know that if you kill me, you’ll bring the guilt of innocent blood on yourselves.” Jeremiah has, in effect, stood up in church and prophesied the destruction of Jerusalem; this made the people furious. He blasphemed the temple, the city, and the mountain of God. Jeremiah did as God told him but it brought a lot of conflict.

Understand, as Jeremiah is making these comments, there are other prophets in Jerusalem. But Jeremiah is the only one speaking for God! The rest are trying to appease the people.

In Jeremiah 27, several years after Chapter 26 occurred, God tells Jeremiah to start wearing a yoke around his neck. He is quite an oddity as he walks around with this contraption. This is the type of yoke oxen or mules wore. Imagine people looking at him and how puzzled they were.

God sometimes goes to dramatic lengths to grab people’s attention. But, we’re so dull and ignorant, we don’t understand; we can’t see or hear. Remember how God required Isaiah to walk around naked for three years with his buttocks bared? (Isaiah 20:1–4)

Notice what happens next: there’s a showdown in Jeremiah 28. The setting is Jerusalem and God’s response is recorded in Ezekiel 13.

Jeremiah 28:1, **“In the fifth month of that same year, the fourth year, early in the reign of Zedekiah king of Judah, the prophet Hananiah son of Azzur, who was from Gibeon, said to me in the house of the Lord in the presence of the priests and all the people.”**

One morning at church when everybody was gathered, Hananiah, the prophet, stood up to speak.

**Jeremiah 28:2-4, “This is what the Lord Almighty, the God of Israel, says: ‘I will break the yoke of the king of Babylon. Within two years I will bring back to this place all the articles of the Lord’s house that Nebuchadnezzar king of Babylon removed from here and took to Babylon. I will also bring back to this place Jehoiachin son of Jehoiakim king of Judah and all the other exiles from Judah who went to Babylon,’ declares the Lord, ‘for I will break the yoke of the king of Babylon.’”**

Nebuchadnezzar has set siege to Jerusalem twice already and it is under his control again. Understand that Zedekiah, the current king, is just a puppet Nebuchadnezzar has placed on the throne. Jehoiachin is the young king of Jerusalem that only reigned for three months before Nebuchadnezzar deposed him in 597 bc.

Hananiah is predicting that Jehoiachin will be brought back as king. And then he says, “The Lord declared it!” Jeremiah then responds.

**Jeremiah 28:5-9, “Then the prophet Jeremiah replied to the prophet Hananiah before the priests and all the people who were standing in the house of the Lord. He said, ‘Amen! May the Lord do so! May the Lord fulfill the words you have prophesied by bringing the articles of the Lord’s house and all the exiles back to this place from Babylon. Nevertheless, listen to what I have to say in your hearing and in the hearing of all the people: From early times the prophets who preceded you and me have prophesied war, disaster and plague against many countries and great kingdoms. But the prophet who prophesies peace will be recognized as one truly sent by the Lord only if his prediction comes true.’”**

The people are getting a real show: two prophets contradicting each other. Jeremiah said, “Amen brother! That would be wonderful. May the Lord do as you have said. But now,

listen to what I have to say. Only the prophet that predicts what comes true is of the Lord.”

This made Hananiah so mad he yanked the yoke from around Jeremiah’s neck and broke it, saying, **“This is what the Lord says: ‘In the same way I will break the yoke of Nebuchadnezzar king of Babylon off the neck of all the nations within two years.’”** (Jeremiah 28:11)

After this, Jeremiah had nothing more to say and walked away.

Jeremiah 28:12–17, **“Then Hananiah the prophet took the yoke off Jeremiah’s neck and broke it in pieces. And Hananiah said again to the crowd that had gathered, ‘This is what the Lord says: “Just as this yoke has been broken, within two years I will break the yoke of oppression from all the nations now subject to King Nebuchadnezzar of Babylon.”’** With that, Jeremiah left the Temple area.

Soon after this confrontation with Hananiah, the Lord gave this message to Jeremiah: **‘Go and tell Hananiah, “This is what the Lord says: You have broken a wooden yoke, but you have replaced it with a yoke of iron. The Lord of Heaven’s Armies, the God of Israel, says: I have put a yoke of iron on the necks of all these nations, forcing them into slavery under King Nebuchadnezzar of Babylon. I have put everything, even the wild animals, under his control.”’**

Then Jeremiah the prophet said to Hananiah, **‘Listen, Hananiah! The Lord has not sent you, but the people believe your lies. Therefore, this is what the Lord says: “You must die. Your life will end this very year because you have rebelled against the Lord.”’** Two months later the prophet **Hananiah died.”** (NLT)

I imagine Jeremiah was embarrassed. But how does one prophet prove the superiority of his word over another? Hananiah was a famous prophet. He could have had a television show on Sunday morning. He was well recognized, well

regarded, and well respected by the Jews. They trusted him.

But then, as prophesied, Hananiah died. This is what God thinks of false prophets who claim to speak for Him. Hananiah was the prophet of peace; Jeremiah the prophet of doom. Which message do you think people preferred?

Nebuchadnezzar placed 21-year-old Zedekiah on the throne of Israel. Even at that young age, he knew he had to appease his boss as well as the people. So, to keep the people in line, he appointed priests and prophets who were favorable to him. The priests worked for the king and the king expected them to say whatever was necessary to keep the people subordinate. Sound familiar? Zedekiah's control over his people came through the priests.

This is a perfect example of what will happen during the great tribulation. When God's judgments begin, there will be millions of false prophets endorsing the creation of laws to appease God. This will be the first step in the formation of a global church / state.

When religious and political powers unite the purpose is control. And the historical record of this proves disastrous. Of the 206 nations of today's world, those ruled by a church / state are not democratic, nor are they progressive. Religion is a powerful force and, for the most part, stymies freedom. Religion is binding, that's why they're called institutions.

When this event happens, there will be millions of clergy in opposition to 144,000 *Jeremiahs*. False preachers will align with politicians to create laws mandating the worship of God. This will affect every nation. Worship will become mandatory. This is why in the book of Revelation, Lucifer is called the false prophet. The parallels between Ezekiel and Jeremiah are clearly similar to John's, if you understand what to look for.

After nine years on the throne, Zedekiah became too big for his britches, so Nebuchadnezzar came to remove him for his insolence and rebellion. Many prophets in Jerusalem were

claiming: God's punishment was over and God's blessings would return within two years. This timing was calculated to encourage everyone back to living a normal life, but it had a detrimental effect.

God wanted His people to understand why He was angry about their behavior. The false prophets weren't teaching the lessons that pointed out what the problems really were—they weren't calling sin by its right name. Instead, they were entertaining the people. They were not teaching the truth because the truth hurts. It runs contrary to our carnal nature. What God wants and expects of us isn't comfortable. *That* is the truth!

People like preachers who make them feel good. If you don't believe it, watch a preacher on Sunday morning—just pick one. Jeremiah didn't make anyone feel good that I'm aware of, and neither did Ezekiel, or Isaiah, or Amos, or Joel, or Obadiah, or Nahum, or even Habakkuk. Not one Old Testament prophet made the people feel good. In fact, when Jesus was on earth, I don't find that He made people feel good, either. Yes, they came to see the miracles, to eat the loaves and fishes, to see spectacles and be entertained. But when it came to picking up their cross and following Him, there weren't many.

It is no different today. Preachers are committed to making people feel good. If not, they don't keep their jobs long. It is all about loving the messenger and making the church bigger.

What would you do if Jeremiah came to your church and tore it apart with the Word of the Lord? How would you respond? How did they respond to Jeremiah? Wanting to be entertained is the problem with religion today.

Let's get back to Ezekiel who is in Babylon.

**Ezekiel 13:2–3, “Son of man, prophesy against the false prophets of Israel who are inventing their own prophecies. Say to them, ‘Listen to the word of the Lord. This is what the Sovereign Lord says: What sorrow awaits the false prophets**



**who are following their own imaginations and have seen nothing at all!’” (NLT)**

This is a local prophecy directed at the false prophets. When people claim to speak for the Lord but are making it up, they are cursed.

Ezekiel 13:4, **“O people of Israel, these prophets of yours are like jackals digging in the ruins.”** (NLT) This means the city will lie in ruins shortly.

Ezekiel 13:5, **“They have done nothing to repair the breaks in the walls around the nation. They have not helped it to stand firm in battle on the day of the Lord.”** (NLT)

In ancient times, the wall of the city was their defense—the way they protected themselves from attacking armies. The Lord was supposed to be Israel’s defense, their wall. The idea is that when a piece of the wall fell it needed to be repaired immediately.

We have to understand the language. This verse is referring to a wall in a spiritual sense. God is saying, “You priests and prophets haven’t taken the time to repair the wall—our relationship—your real defense. You haven’t pointed out where the breakdown is occurring among my people. You aren’t exposing the holes in their spiritual lives which are separating them from me. You haven’t repaired the holes so my people can stand firm. You’re leaving them vulnerable to the enemy.”

Ezekiel 13:6–7, **“Instead, they have told lies and made false predictions. They say, ‘This message is from the Lord,’ even though the Lord never sent them. And yet they expect him to fulfill their prophecies! Can your visions be anything but false if you claim, ‘This message is from the Lord,’ when I have not even spoken to you?”** (NLT)

God is saying, “This is nonsense. I didn’t speak to you.”

Ezekiel 13:8–9, **“Therefore, this is what the Sovereign Lord says: Because what you say is false and your visions are a lie, I will stand against you, says the Sovereign Lord. I will**

**raise my fist against all the prophets who see false visions and make lying predictions, and they will be banished from the community of Israel. I will blot their names from Israel's record books, and they will never again set foot in their own land. Then you will know that I am the Sovereign Lord.”**  
(NLT)

Remember those words during the Great Tribulation.

**Ezekiel 13:10–11, “This will happen because these evil prophets deceive my people by saying, ‘All is peaceful’ when there is no peace at all! It’s as if the people have built a flimsy wall, and these prophets are trying to reinforce it by covering it with whitewash! Tell these whitewashers that their wall will soon fall down. A heavy rainstorm will undermine it; great hailstones and mighty winds will knock it down.”**  
(NLT)

This is a crucial point. In 1 Thessalonians 5, Paul says, “When people are crying out for peace and safety, destruction will come.” Hananiah was predicting peace and prosperity when it was never going to happen. The same is happening today.

The judgments of God are coming upon this world because of our rebellion and sinful behavior. And preachers aren’t warning the people. The message today is all about prosperity: using the Lord to get what you want. Preachers today are teaching the people to love God’s *presents* instead of His *presence*.

In fact, when Revelation’s story is presented to these preachers they will reject it, saying, “It’s false.” They will instead proclaim, “Peace. Love Jesus. Be happy!”

Friends, that’s all false! God, in His Word, has laid out a course of action that demands our study and investigation. Yes, believing and trusting in the Lord is necessary, even critical, because peace isn’t coming. God’s wrath is coming and the Book of Revelation, as well as other books in the Bible, clearly explains this time of trouble.

Malachi 2:7–8 says, “**The words of a priest’s lips should preserve knowledge of God, and people should go to him for instruction, for the priest is the messenger of the Lord of Heaven’s Armies. But you priests have left God’s paths. Your instructions have caused many to stumble into sin. You have corrupted the covenant I made with the Levites,’ says the Lord of Heaven’s Armies.**” (NLT)

Look at Ezekiel 13:10 again. It says, “Because they lead my people astray, saying, ‘Peace,’ when there is no peace, and because, when a flimsy wall is built, they cover it with whitewash.” The priests made excuses for not building a strong relationship and then covered up the necessity of having one.

Ezekiel 13:12–16, “**And when the wall falls, the people will cry out, ‘What happened to your whitewash?’ Therefore, this is what the Sovereign Lord says: I will sweep away your whitewashed wall with a storm of indignation, with a great flood of anger, and with hailstones of fury. I will break down your wall right to its foundation, and when it falls, it will crush you. Then you will know that I am the Lord. At last my anger against the wall and those who covered it with whitewash will be satisfied. Then I will say to you: ‘The wall and those who whitewashed it are both gone. They were lying prophets who claimed peace would come to Jerusalem when there was no peace. I, the Sovereign Lord, have spoken!’**” (NLT)

It makes God angry when people claim He has spoken, when He hasn’t. So don’t say, “God told me” or “God showed me,” when He hasn’t. God has not promised peace for this earth. He has determined wrath. And understanding *why* is important.

The prophecies of Ezekiel particularly relate to the people living at the time of Ezekiel—the nation of Israel in ancient time. They have nothing to do with people living in the modern state of Israel in modern times.

In drawing 4.1, the black line represents the span of time

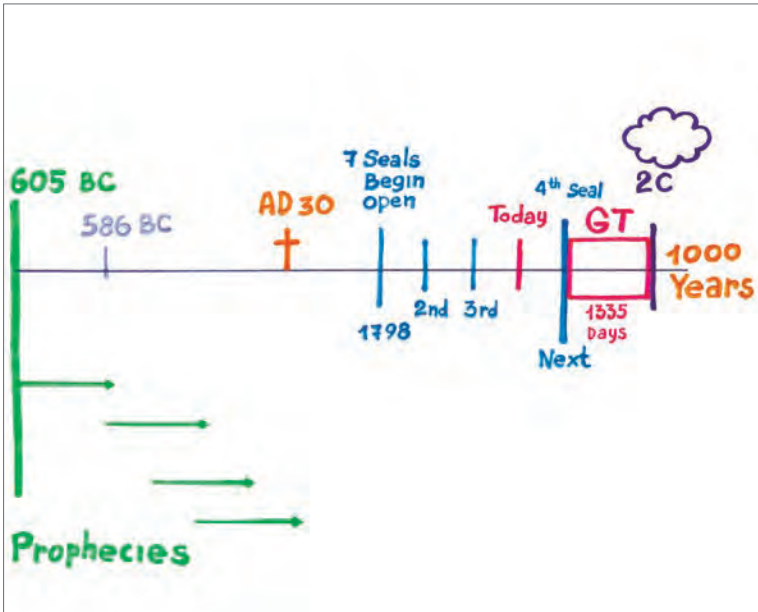

*Drawing 4.1*

Ezekiel lived in 586 bc. The orange cross represents the time of Christ in ad 30 when He was crucified. We are living at the pink line today.

God has, in the book of Daniel, given us prophecies that started in 605 bc. These are represented by green arrows progressing to the right, and these prophecies are moving forward as we go through time.

In Revelation, a number of prophecies focus on a period of time that is just ahead of us called the great tribulation (GT).

During the great tribulation (GT), mankind will experience traumatic consequences. The Bible says, the great tribulation lasts 1,335 days. (Daniel 12:11–12) The seven seals (in blue) began opening in 1798 of which three have been opened thus far. The great tribulation begins with the opening of the fourth seal. It is the next to open.

I don't know how many days are between today and the

opening of the fourth seal. It could be one day, it could be ten years—no one knows. However, the Bible gives a chronological order of events so that we may know the sequence. When Jesus comes (2C in purple), the sabbatical millennium begins.

Revelation 6:7–8 says, **“When the Lamb opened the fourth seal, I heard the voice of the fourth living creature say, ‘Come!’ I looked, and there before me was a pale horse! Its rider was named Death, and Hades was following close behind him. They were given power over a fourth of the earth to kill by sword, famine and plague, and by the wild beasts of the earth.”**

When the fourth seal opens, twenty-five percent of earth’s population is going to perish by sword, famine, plague, and wild beasts—God’s four deadly judgments. This is His wrath against rebellion.



## chapter 5



# Israel's Cup Of Iniquity

In Ezekiel 14:1–3, Ezekiel recounts, “Some of the elders of Israel came to me and sat down in front of me. Then the word of the Lord came to me: ‘Son of man, these men have set up idols in their hearts and put wicked stumbling blocks before their faces. Should I let them inquire of me at all?’

Therefore speak to them and tell them, ‘This is what the Sovereign Lord says: When any of the Israelites set up idols in their hearts and put a wicked stumbling block before their faces and then go to a prophet, I the Lord will answer them myself in keeping with their great idolatry. I will do this to recapture the hearts of the people of Israel, who have all deserted me for their idols.’

Therefore say to the people of Israel, ‘This is what the Sovereign Lord says: Repent! Turn from your idols and renounce all your detestable practices! When any of the Israelites or any foreigner residing in Israel separate themselves from me and set up idols in their hearts and put a wicked

stumbling block before their faces and then go to a prophet to inquire of me, I the Lord will answer them myself. I will set my face against them and make them an example and a byword. I will remove them from my people. Then you will know that I am the Lord.

And if the prophet is enticed to utter a prophecy, I the Lord have enticed that prophet, and I will stretch out my hand against him and destroy him from among my people Israel. They will bear their guilt—the prophet will be as guilty as the one who consults him. Then the people of Israel will no longer stray from me, nor will they defile themselves anymore with all their sins. They will be my people, and I will be their God, declares the Sovereign Lord.’”

Can we approach the Lord with wickedness in our heart? No. The text uses a word that isn’t used much today but has significant meaning. A *byword* is a memorable saying like a proverb. It is used here as a reproach. Don’t treat the Lord casually or with contempt. Other than claiming to speak for God, one of the most distressing things I hear today is people carelessly using God’s name. They use it without realizing the holiness of the name they’re invoking.

The third commandment says not to use the name of the Lord carelessly. We are not to mention His name except in a spirit and attitude of reverence because we’re talking about the Almighty. Be careful with His name. When people understand that God requires a pure heart, that He’s not going to play along with wickedness, most will rethink their actions.

Ezekiel 14:12–23, “**The word of the Lord came to me: ‘Son of man, if a country sins against me by being unfaithful and I stretch out my hand against it to cut off its food supply and send famine upon it and kill its people and their animals, even if these three men—Noah, Daniel and Job—were in it, they could save only themselves by their righteousness, declares the Sovereign Lord.**

Or if I send wild beasts through that country and they



leave it childless and it becomes desolate so that no one can pass through it because of the beasts, as surely as I live, declares the Sovereign Lord, even if these three men were in it, they could not save their own sons or daughters. They alone would be saved, but the land would be desolate.

Or if I bring a sword against that country and say, “Let the sword pass throughout the land,” and I kill its people and their animals, as surely as I live, declares the Sovereign Lord, even if these three men were in it, they could not save their own sons or daughters. They alone would be saved.

Or if I send a plague into that land and pour out my wrath on it through bloodshed, killing its people and their animals, as surely as I live, declares the Sovereign Lord, even if Noah, Daniel and Job were in it, they could save neither son nor daughter. They would save only themselves by their righteousness.

For this is what the Sovereign Lord says: How much worse will it be when I send against Jerusalem my four dreadful judgments—sword and famine and wild beasts and plague—to kill its men and their animals! Yet there will be some survivors—sons and daughters who will be brought out of it.

They will come to you, and when you see their conduct and their actions, you will be consoled regarding the disaster I have brought on Jerusalem—every disaster I have brought on it. You will be consoled when you see their conduct and their actions, for you will know that I have done nothing in it without cause, declares the Sovereign Lord.’”

God was claiming responsibility, saying, “If a nation becomes so evil that it has to be destroyed, I will destroy it; I will not spare it.” Verse 13 on is talking about nations, which means all countries.

God’s judgments are not symbolic. They are very real. God was saying this as straightforward as He could. Bloodline

doesn't mean anything to God. He is not concerned with who our daddy is.

In Revelation 6:7-8, John saw the fourth seal opened. Ezekiel describes the same four judgments which are soon to come upon the world. In Revelation 8 and 9, we find the circumstances that cause these four judgments to fall. What Jeremiah was saying to the people in Jerusalem, Revelation is saying to us today. God's four judgments will cause astounding destruction and loss of life.

\* \* \* \* \*

I need to illustrate an important concept in drawing 5.1 as we study the prophecies of *Plan B*.

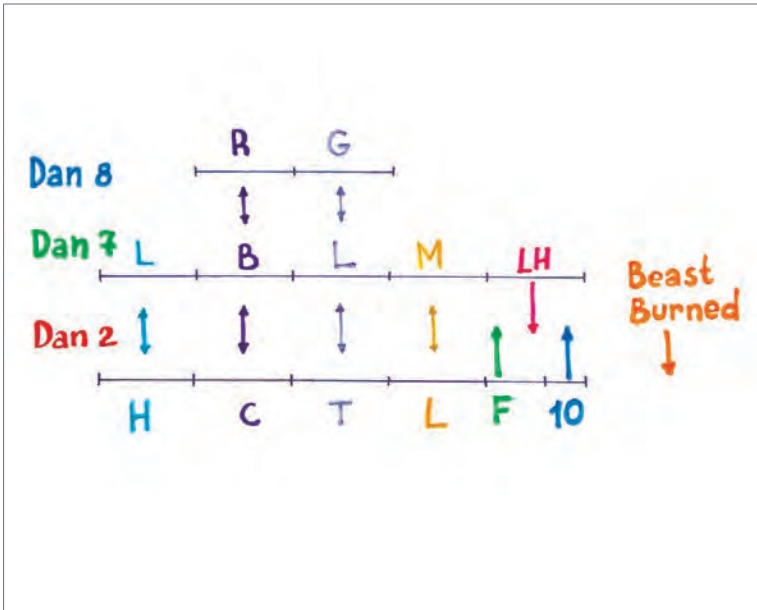

Drawing 5.1

In Daniel 2, we have the head of gold, chest of silver, thighs of brass, legs of iron, feet of iron and clay, and ten toes of iron and clay. In Daniel 7, there is a lion, a bear, a leopard, a monster, and a little horn coming out of the monster, then at the

end, the beasts are burned in the fire.

Consider the matrix this produces. There is a parallel between the lion and the head of gold, the bear and the chest of silver, the leopard and the thighs of brass, the monster beast of Rome and the legs of iron. Then we go to Daniel 8 and begin another prophecy that features a ram and a goat.

The Bible tells us the ram and goat represent the kingdoms of Medo-Persia and Greece. Medo-Persia, represented by the ram, has two horns; history confirms one of the horns rose higher than the other. Like the bear, one shoulder rose higher, indicating the Persian side of the kingdom would become dominant.

In detailing this unfolding matrix, I am showing its repetition and enlargement. For example, we see the ram also represents the bear, which also represents the chest of silver, which also represents the kingdom of the Medes and the Persians. The same is true of the goat: its notable horn is Alexander the Great, and after he was *broken off*, four horns arose in his place. This parallels the leopard beast which has four heads. It also represents the thighs of brass because the Bronze Age comes with the Grecian kingdom. Revelation has a similar matrix.

\* \* \* \* \*

Revelation 7:1–4 says, **“After this I saw four angels standing at the four corners of the earth, holding back the four winds of the earth to prevent any wind from blowing on the land or on the sea or on any tree. Then I saw another angel coming up from the east, having the seal of the living God. He called out in a loud voice to the four angels who had been given power to harm the land and the sea: ‘Do not harm the land or the sea or the trees until we put a seal on the foreheads of the servants of our God.’ Then I heard the number of those who were sealed: 144,000 from all the tribes of Israel.”**

No wind of God's wrath can blow until this sealing is

completed. God tells these four angels not to harm the land, sea, or trees until the 144,000 are sealed. I understand this to mean that after the 144,000 are sealed, the land, sea, and trees are going to be *hammered*.

Revelation 8:6–12 follows the sealing, **“Then the seven angels with the seven trumpets prepared to blow their mighty blasts. The first angel blew his trumpet, and hail and fire mixed with blood were thrown down on the earth. One-third of the earth was set on fire, one-third of the trees were burned, and all the green grass was burned. Then the second angel blew his trumpet, and a great mountain of fire was thrown into the sea. One-third of the water in the sea became blood, one-third of all things living in the sea died, and one-third of all the ships on the sea were destroyed.**

**Then the third angel blew his trumpet, and a great star fell from the sky, burning like a torch. It fell on one-third of the rivers and on the springs of water. The name of the star was Bitterness. It made one-third of the water bitter, and many people died from drinking the bitter water. Then the fourth angel blew his trumpet, and one-third of the sun was struck, and one-third of the moon, and one-third of the stars, and they became dark. And one-third of the day was dark, and also one-third of the night.”** (NLT)

God’s four judgments are within the trumpets of Revelation. The great tribulation could begin any day, and a great earthquake will mark its commencement. After the great earthquake (the opening of the fourth seal), the angels start blowing their horns. In verse 8, *huge mountain* means an *asteroid impact*. What would you call a one-mile-high rock sitting on your front lawn? A mountain! What words would John need to use to describe an asteroid flying through space at sixty thousand miles per hour? A mountain all ablaze is about the best way to describe it.

What is this depicting? One-third of the land is destroyed, one-third of the crops are burned up, and the sea is impacted.

God told Ezekiel He would use His four judgments against Jerusalem, and this is a parallel of how they will be used against the world. God's wrath is clearly defined in Revelation. Yet, we also find salvation as well. He will go through the earth and determine who can be saved.

I am deliberately moving slowly through Ezekiel. A proper understanding requires us to stand where he stood and think as he thought. This takes quality time. Letting a pastor tell us what to believe won't work. We have to understand the setting of Ezekiel's day in order to understand his conversations with God.

Ezekiel is a Jew, a captive in Babylon. He's timid. He saw Jerusalem captured with his own eyes. These issues affect his personal views about God and Israel's relationship with God. So to understand what Ezekiel is saying, let's investigate.

Many people take Ezekiel's words out of context, distorting them to support ideas and conclusions that have nothing to do with what Ezekiel wrote. This happens throughout the entire Bible. I am sensitive to this issue because I have experienced it.

What I write (and write about) is controversial. Generally, two types of people respond to my opinions. The first honestly try to understand what I say; they may not agree, but at least their attitudes, comments, and questions reveal their honesty and integrity. The second, which is unfortunately the larger group, consists of those who believe I am wrong before they examine what I've said. They know I am wrong because it is contrary to what they believe. These people have no interest in understanding what I teach. I am not saying that everyone who disagrees with me is intellectually dishonest. I am saying that people who distort the meaning of my words to make me say what I never intended, are being duplicitous.

After a writer dies, it is practically impossible to determine the honesty (or dishonesty) of those who report his views. This is precisely the case with Ezekiel. We must read his writings carefully and understand the setting in which they took place.

There is no other way to tell if a teacher is manipulating Ezekiel's words to support his own message or not.

That is why I have spent so much time laying the groundwork for the Book of Ezekiel. I want you to know him, to understand the issues of his day. There is a big difference between studying the Bible and reading it. You have to be intimately acquainted with its parts and pieces. How tragic to listen to someone who is supposedly teaching others but can't give an accurate account of what was taking place in Ezekiel.

How do we allow the Bible to tell us things we don't want to believe? It is only possible if we are careful in our study of God's Word. To help us understand all sixty-six books of the Bible, God graciously had Bibles printed enabling us to study for ourselves. But few people really study their Bible; the Internet is more interesting. We are too busy. It is much easier to go to church and have a preacher tell us what to think. The United States is becoming an idolatrous nation filled with ignorant people. We live in an age of marvelous enlightenment, and yet, there is great ignorance about God's Word.

The words of Hosea still ring true. **“Hear the word of the Lord, you Israelites, because the Lord has a charge to bring against you who live in the land: ‘There is no faithfulness, no love, no acknowledgment of God in the land. There is only cursing, lying and murder, stealing and adultery; they break all bounds, and bloodshed follows bloodshed.’”** (Hosea 4:1-2)

Hosea 4:5-6, **“You stumble day and night, and the prophets stumble with you. So I will destroy your mother [your nation]—my people are destroyed from lack of knowledge. ‘Because you have rejected knowledge, I also reject you as my [nation of] priests; because you have ignored the law of your God, I also will ignore your children.’”**

God gave Israel instruction in righteousness, and knowledge about His ways, covenant, and wonderful laws. The people were ignorant because they rejected knowledge. This is

what the *lack of knowledge* means?

**“The more priests there were, the more they sinned against me; they exchanged their glorious God for something disgraceful. They feed on the sins of my people and relish their wickedness. And it will be: Like people, like priests. I will punish both of them for their ways and repay them for their deeds.”** (Hosea 4:7–9) It should be the other way around—like priest, like people.

Hosea was a prophet to the ten northern tribes. During his ministry in 722 BC, Shalmaneser V destroyed Israel for rejecting God’s message. Hosea witnessed it with his own eyes.

The drama takes a while to make sense but after it becomes familiar, we can grasp how God constantly deals with the sin problem. God’s management of earth is governed by eternal policies which are revealed throughout the Old Testament. Because Jeremiah, Ezekiel, and Daniel were living at the same time, we can easily align God’s comments to Ezekiel with His comments to Jeremiah and Daniel, thus understand what these policies are.

Keep in mind that when the leadership of a nation becomes hopelessly corrupt, God inflicts corporate punishment on that nation to produce a regime change. Unfortunately, when God inflicts corporate punishment the innocent also suffer. When Israel and Judah violated seventy Sabbath years, God sent them into Babylonian captivity. Ezekiel and Daniel were taken as captives.

I am not saying every individual contributed to filling up Israel’s cup of iniquity, but the majority had. Seven times in the book of Ezekiel, God assures the captives that He would return them to Jerusalem. The references are Ezekiel: 11:16; 20:40; 28:25; 34:13; 36:24; 37:21; and 39:28.

These verses are assurances of restoration. God informed Jeremiah, Ezekiel, and Daniel about the restoration of Israel which would occur at the end of the seventy-year captivity.

God was not talking to Ezekiel about the creation of a nation called Israel in 1948. Millions of Christians have been misled. God was talking about an opportunity for Israel to be restored as His chosen people at the end of their captivity. However, they refused His offer. God told Daniel, the appearing of Messiah would be connected to a decree restoring the city and the temple. It has nothing to do with 1948.

God said through Gabriel, **“Know and understand this: From the time the word goes out to restore and rebuild Jerusalem until the Anointed One, the ruler, comes, there will be seven ‘sevens,’ and sixty-two ‘sevens.’ It will be rebuilt with streets and a trench, but in times of trouble.”** (Daniel 9:25)

Ezekiel and Daniel were talking about Israel’s return out of Babylonian captivity. In fact, the restoration of Israel was predicted by ten Old Testament prophets. They were not talking about the last days of earth’s history. They were talking about the restoration of Israel that would have occurred had Israel been faithful.

There would have been no second coming had Israel been faithful at Jesus’ first coming. The Old Testament does not speak of a second coming, except in Daniel, and his book was sealed up until the time of the end. It was recorded for those who will live then. And if *Plan A* had been implemented, Daniel’s book would have never been unsealed.

Look at Jeremiah 25:8, **“Therefore the Lord Almighty says this: ‘Because you have not listened to my words.’”** The context is prior to Babylonian captivity. Verse 12, **“But when the seventy years are fulfilled, I will punish the king of Babylon and his nation, the land of the Babylonians, for their guilt, declares the Lord.”**

Jeremiah 16:14–15, **“‘However, the days are coming,’ declares the Lord, ‘when it will no longer be said, “As surely as the Lord lives, who brought the Israelites up out of Egypt,” but it will be said, “As surely as the Lord lives, who brought the Israelites up out of the land of the north and out of all**



**the countries where he had banished them.” For I will restore them to the land I gave their ancestors.’”**

This is talking about post-Babylonian restoration, not post-WW2 creation. View this from the framework of ancient Israel, not modern Israel. If you don't, the result will be a distortion of God's Word. The context of what ten prophets say in the Old Testament fully supports my conclusion. There was no second coming planned under *Plan A*. There was only a plan for a first coming.

God had a plan when He delivered Israel out of Egyptian slavery. He wanted to take them into the Promised Land. But after two years, when ten of the twelve spies murmured against Him, He refused to let them enter; and that generation (all but Caleb and Joshua) died in the desert. Starting with a new generation, He tried again.

God has an original plan—*Plan A*—but each time He starts over, He implements the next plan, *Plan B*. There are repetitious subroutines of this *Plan A / Plan B* throughout the Bible. It happens over and over.

There was no mention of the second coming in the Old Testament because it was God's intention that there would be no second coming. The second coming is *Plan B*. And *Plan B* is only necessary because the first coming (*Plan A*) didn't work out.

If you understand what *Plan A* was to have been in the Old Testament, then your understanding of what will happen under *Plan B* in the New Testament will make a lot more sense. But, if you mix *Plan A* with *Plan B*, you create a nightmare of prophetic explanation that has nothing to do with what God's plans really are.

This is *Plan A* in its simplest terms as I understand it. God created Adam and Eve and placed them in the Garden of Eden. He gave them everything they could ever need, then they sinned. Thus the need for *Plan B* (the Plan of Salvation) had to

be put in motion to redeem fallen man. God didn't cause *Plan B* to have to be implemented. Adam and Eve did it by sinning. Yet, were it not for the mercy of God, there would have been no *Plan B*, and Adam and Eve would have been destroyed immediately. God had promised when they ate of the fruit, they would surely die. But Jesus stepped in the way and became man's intercessor.

In *Plan A*, God set the couple in a happy home and wanted them to live there for eternity. *Plan B* brings about the restoration of sinners so they can go back to the Garden of Eden where they were supposed to have been all along. When the psalmist wrote, "He restoreth my soul," he implied that God was going to put it back like it was before sin. The entire Bible is about humanities' *Plan B*. Eden lost, Eden restored.

When God delivered Israel from Egyptian slavery, He knew that Israel would rebel. They wouldn't put their faith in Him and would instead continue in idolatry. However, God doesn't treat us based on His foreknowledge, He treats us on the basis of His love for us—on what He knows is best. Isn't that what a good parent does?

God knew Adam and Eve would sin but He didn't treat them on that basis until they had. He doesn't use His foreknowledge to manipulate our choices. God rescued Israel from Egyptian slavery, but in the wilderness they rejected Him. As a *Plan B*, God killed off that generation in the desert and started with a new group.

It is interesting that God didn't have the new generation send in spies. He just took them into the Promised Land and started over. Unfortunately, that generation rebelled during the period of the Judges. They cycled through seven periods of rebellion, repentance, and reformation—*Plan A*, *Plan B*; *Plan A*, *Plan B*.

In the story of Gideon, God was punishing Israel for their rebellion. He was going to start over with another *Plan A* and raised Gideon to destroy the Midianites. But after Gideon died,

God again had to deal with a rebellious generation.

God had to start over with a new *Plan A* many times because Israel constantly rebelled. Eventually, Israel split into two nations at Solomon's death with Jeroboam and Rehoboam as their kings. Finally, after putting up with the rebellion of the northern ten tribes for around three hundred years, God had had enough; they had finally used up *Plan Z* to no avail. Since there were no more *plans* available for the northern kingdom, God sent Shalmaneser V to destroy them, then waited to see what the two southern tribes would do.

Well, Judah and Benjamin also rejected God. He then killed two-thirds of them, removed the survivors to Babylon, and had the city destroyed. While in Babylon, God told the captives there would be one last *Plan A*, and it would endure for a period of 70 weeks—490 years.

God promised that Messiah Himself would appear during the 70<sup>th</sup> week. Many wonderful things were promised under this last new start. BUT, all of the promises were aborted when Israel rebelled yet again.

John 1:11 says, **“He came to that which was his own, but his own did not receive him.”** Here is the critical point where millions of Christians get lost. When Israel rejected Messiah, all that *Plan A* was offering to renew since post-Babylonian captivity was aborted.

When it became clear that Israel would reject the Messiah again, God rejected the nation of Israel for the final time. He then implemented a *Plan B* that was radically different from anything He had done before. Under this *Plan B*, God redefined Israel.

In Galatians 3, Paul makes it clear that believers in Christ are now considered Abraham's sperm—his offspring. In Greek, the word translated for seed is *sperma*. God considers believers in Christ to be Abraham's seed, so that all three of the essential promises made to Abraham can and will be fulfilled. Jesus told

His disciples in John 14 that He was going back to heaven, and there, prepare houses for His children. Old Jerusalem would be destroyed. This happened in AD 70.

Under *Plan B*, God added more prophecy to accompany the Book of Daniel. We have the explanation of the prophetic course of events in the Book of Revelation. Daniel and Revelation belong to *Plan B*. This is why Daniel was sealed until the end of time, so that if *Plan B* should become necessary, the two books would be revealed and understood as confirmation that *Plan B* was now being implemented.

*Plan B* has a better covenant than *Plan A* because it's based, not on the blood of animals, but on the blood of Jesus. The shedding of blood made both covenants a blood covenant, but of course, the blood of Jesus is superior to the blood of an animal.

Because *Plan B* was implemented, a new prophetic sequence of events now unfolds. Everything God promised to Israel was fulfilled, as far as Israel would allow God to go. God was faithful to His covenant with them but Israel was unfaithful and their unfaithfulness terminated the covenant.

If a man or woman is unfaithful to the marriage covenant, it is appropriate to terminate the covenant. God permits it. And so it was with God's covenant with ancient Israel. Israel abandoned the covenant, so God terminated it along with its plans for the biological offspring of Abraham. He then redefined Israel as believers in Christ and put *Plan B* into motion.

Some of *Plan B's* end-time events are parallels of the end-time events that would have taken place under *Plan A*. As stated earlier, the Old Testament says nothing about a second coming in *Plan A*. The prophecies in Daniel refer to *Plan B*, not *Plan A*. It wasn't mentioned because there was to only be a first coming. Messiah was to be received by the Jews and His kingdom established here on earth when He came the first time. Read the Old Testament prophets in their right context without trying to make it fit in our day. Their prophecies will

make sense just as they read.

When we get to Ezekiel 34–38, which discusses the valley of the dry bones and Gog and Magog, we will see the prophecy has nothing to do with the second coming or the end of time. Instead, it has to do with the first coming and what would have happened had Israel been faithful under *Plan A*.

Because God started over after the Jews rejected Messiah, we are living under *Plan B*. However, if we mix the prophetic details of the two plans, it creates a false prophetic interpretation. It won't work! What Daniel and Revelation say conflict with Jeremiah and Ezekiel. Not because the Bible is contradictory, but because they offer two different plans.

There are parallels between *Plan A* and *Plan B*, but they never share the same fulfillment. This means that significant portions of the Old Testament will never be fulfilled because they belong to *Plan A*, which was abandoned while Jesus was on earth.

Matthew 23:37–38, **“Jerusalem, Jerusalem, you who kill the prophets and stone those sent to you, how often I have longed to gather your children together, as a hen gathers her chicks under her wings, and you were not willing. Look, your house is left to you desolate.”**

Jesus is the God of the Old Testament, the one who dealt with Israel 1,400 years before He came in human form. He is Jehovah God here in the flesh sitting on the mount looking over the city. In these verses Jesus defines the ultimate problem, **“You were not willing.”**

A desolate house means an empty temple. An empty temple means God has abandoned it. It was destroyed in AD 70 never to be rebuilt. The rebuilding and restoration mentioned in Daniel is the post Babylonian exile—nothing more. If the Jews had accepted Jesus, He would not have returned to heaven at the end of the 70 weeks, but remained on earth to establish His kingdom and fulfill *Plan A*.

John 12:34 says, **“The crowd spoke up, ‘We have heard from the Law that the Messiah will remain forever.’”**

After a few years of preparation, the twelve tribes would have been sent throughout the world to gather in a great harvest as described in Isaiah 19 and 43. After the ingathering of all the precious souls, Lucifer would have been empowered to attack Jerusalem to destroy it. But Jesus would have destroyed Lucifer and all of the wicked. This is detailed in Ezekiel 36–38 and Zechariah 14.

I know some who read this will disagree with my understanding without ever reading the Bible or studying the matter for themselves. People believe I have the strangest ideas about what the Bible teaches, but can’t explain the simplest of doctrines. This is called being under the Influence of religion. People are lazy in their study of God’s Word. The Devil knows that if he can keep people from studying their Bible, they will become separated from God. This is what happened to Israel in the Book of Ezekiel. The people were very religious, yet didn’t know God.

I encourage you to take your Bible and see what it says for yourself. Know why you believe what you believe. “My pastor told me,” is not good enough. I have read *Foxe’s Book of Martyrs*—you should too—and I don’t recall one martyr who went to his death because his preacher thought he should. You have to know God’s Word for yourself!

## chapter 6



# God Changed Plans

God had three prophets speaking at the same time from different locations. What each said must be merged to really understand the complete story.

The people who remained in Jerusalem after the second siege were awaiting their final destruction, which would come five years hence. Ezekiel 20 was written in 591 BC, but the siege of the city lasted 18 months before it was totally destroyed. Understand that God was talking to Daniel about an entirely different plan than Ezekiel. God is talking to Daniel about *Plan B*; Ezekiel and Jeremiah are receiving *Plan A*.

God was talking *Plan A* and *Plan B* at the same time, but sealed up *Plan B* until Israel made a choice during the 70 weeks granted them. God surely gives us more grace than we deserve. I am so grateful for the mercies, goodness, and patience extended to me.

Ezekiel 20:1, **“In the seventh year, in the fifth month on the tenth day, some of the elders of Israel came to inquire of**

**the Lord, and they sat down in front of me.”** This event was being dated according to the seventh year of King Jehoiachin’s imprisonment in Babylon—around August of 591 BC.

Ezekiel 20:2–3, **“Then the word of the Lord came to me: ‘Son of man, speak to the elders of Israel and say to them, ‘This is what the Sovereign Lord says: Have you come to inquire of me? As surely as I live, I will not let you inquire of me, declares the Sovereign Lord.’”**”

The Lord is saying, “I am not going to talk to the elders.”

Ezekiel 20:4–7, **“Will you judge them? Will you judge them, son of man? Then confront them with the detestable practices of their ancestors and say to them: ‘This is what the Sovereign Lord says: On the day I chose Israel, I swore with uplifted hand to the descendants of Jacob and revealed myself to them in Egypt. With uplifted hand I said to them, ‘I am the Lord your God.’ On that day I swore to them that I would bring them out of Egypt into a land I had searched out for them, a land flowing with milk and honey, the most beautiful of all lands. And I said to them, ‘Each of you, get rid of the vile images you have set your eyes on, and do not defile yourselves with the idols of Egypt. I am the Lord your God.’”**”

He is saying, “Ezekiel, explain why I won’t speak to them.” An uplifting of the hand means He had taken an oath. It is clear that God wanted to give the best to Abraham’s family.

Verse 7 refers to Moses’ journey to Egypt after the burning-bush event. The first request Moses made of Pharaoh was, *“Let my people go for three days into the desert to make sacrifices to the Lord or He’s going to kill us with the sword.”* God is concerned about the idolatry Israel had begun to practice during their stay in Egypt.

The Book of Exodus doesn’t say much about Israel’s conduct in Egypt. Yet, as we go forward about nine hundred and fifty years to the time of Ezekiel, God reveals things that happened



back then. It all comes together very harmoniously once seen from God's perspective. He is saying, "I am the Lord; I am your Savior. You have been slaves in Egypt for generations, worshiping images that cannot deliver you. They didn't deliver you, I did."

**Ezekiel 20:8–12, "But they rebelled against me and would not listen to me; they did not get rid of the vile images they had set their eyes on, nor did they forsake the idols of Egypt. So I said I would pour out my wrath on them and spend my anger against them in Egypt. But for the sake of my name, I brought them out of Egypt. I did it to keep my name from being profaned in the eyes of the nations among whom they lived and in whose sight I had revealed myself to the Israelites. Therefore I led them out of Egypt and brought them into the wilderness. I gave them my decrees and made known to them my laws, by which the person who obeys them will live. Also I gave them my Sabbaths as a sign between us, so they would know that I the Lord made them holy."**

When Moses arrived in Egypt with the message of deliverance, he was faced with rebellion because he demanded they put away their vile idols. They wouldn't. God would have spent His anger against Israel for their rebellion in Egypt. But He waited. When Moses went to Pharaoh and asked for the three days and Pharaoh refused, God then implemented a *Plan B*. This story isn't in the book of Exodus, it is in the book of Ezekiel. And only by studying the Bible—putting its pieces together—can we appreciate God's love and patience.

The word *live* as used in verse 11, should be translated *prosper*. God created good laws based on infinite wisdom and He did this so man would prosper. In verse 12, the seventh-day Sabbath is one of the laws meant to benefit mankind. It is God's gift to man; a very special gift! Here is a simple overview of the Sabbath.

In Exodus 5, God told Moses that if the Israelites wanted to be delivered from slavery they would have to stop working on

the Sabbath. This put them in a difficult situation. They had been worshipping idols, but wanted to be set free. When they began keeping the Sabbath, Pharaoh made them gather their own straw while producing the same number of bricks.

Scholars have debated whether the work stoppage was to observe God's Sabbath. Even though no text specifically says the slaves rested on the seventh day, the harmony of these four points resolves the question for me.

(1) From creation to Mt. Sinai, a period of about 2,500 years, the only day set aside for rest is God's Sabbath, the seventh day of the week. (Genesis 2:2–3; Exodus 20:8–11)

(2) Before God spoke the Ten Commandments on Mt. Sinai, He tested Israel to see if they would observe His Sabbath. (Exodus 16:4) This test proves: First, God's seventh day *was holy* prior to the Ten Commandments. (Genesis 2:1–3) Second, God required Israel *to observe* His Sabbath before He publicly made the Ten Commandments known.

(3) God demands His subjects observe the Sabbath day of the fourth commandment. True worship is joyful submission to His demands. The Ten Commandments are not suggestions—they are laws.

(4) The word Pharaoh used *sabat* (H7673) suggests that Moses and Aaron led Israel to rest from their labor. In Exodus 5:5, Pharaoh said to Aaron and Moses, “**You make them rest from their labor!**” (NKJV) Or, “**You are stopping them from working.**” (NIV)

This verse indicates: First, Pharaoh appropriately charged Aaron and Moses with causing the Israelites to cease work. Second, the Hebrew word used by Pharaoh is the same word used in Genesis 2:2 when God rested on the seventh day of creation week.

These points demonstrate to me Israel was not honoring God's Sabbaths. Their allegiance to God's demand put Israel in direct opposition to Pharaoh's demand. This is exactly what

God wanted. The end-time parallel will be no different.

Faith, obedience, and deliverance are inseparable when it comes to worshipping God. It is impossible for a person to knowingly defy God's sovereignty and simultaneously enjoy God's favor. Israel had to submit. Human nature does not like the seventh-day Sabbath. We want our time for our own pleasure.

But God says, "No, it doesn't work that way. If you love me and are willing to keep my Sabbaths, I will give you rest. If you will trust me, I'll make sure you don't lose anything. You may lose your job or your friends, I'll replace them." It is a test of faith. The Sabbath has always been a sign because it stands contrary to the ways of the world.

People can have different motives for keeping the Sabbath, but eventually, if you don't have a correct understanding of God's intent it will become corrupted. When Jesus came to earth there were four hundred and thirteen regulations concerning Sabbath observance. It had become a burden. It wasn't about living by faith—depending on God and resting on His promises—it was about works; another form of rebellion under the guise of keeping the Sabbath.

Remember, Israel was tested on the Sabbath even before God presented the Ten Commandments. The root problem was idolatry. When anything is put in God's place it is idolatry. This was the case with Israel. They wanted to live life their way.

**Ezekiel 20:13–20, "Yet the people of Israel rebelled against me in the wilderness. They did not follow my decrees but rejected my laws—by which the person who obeys them will live—and they utterly desecrated my Sabbaths. So I said I would pour out my wrath on them and destroy them in the wilderness. But for the sake of my name I did what would keep it from being profaned in the eyes of the nations in whose sight I had brought them out. Also with uplifted hand I swore to them in the wilderness that I would not bring them into the land I had given them—a land flowing with**

milk and honey, the most beautiful of all lands—because they rejected my laws and did not follow my decrees and desecrated my Sabbaths. For their hearts were devoted to their idols. Yet I looked on them with pity and did not destroy them or put an end to them in the wilderness. I said to their children in the wilderness, ‘Do not follow the statutes of your parents or keep their laws or defile yourselves with their idols. I am the Lord your God; follow my decrees and be careful to keep my laws. Keep my Sabbaths holy, that they may be a sign between us. Then you will know that I am the Lord your God.’”

The Sabbath is a big deal to God. We show the quality of our relationship with Him by keeping His Sabbath holy.

Ezekiel 20:21–26, **“But the children rebelled against me: They did not follow my decrees, they were not careful to keep my laws, of which I said, ‘The person who obeys them will live by them,’ and they desecrated my Sabbaths. So I said I would pour out my wrath on them and spend my anger against them in the wilderness. But I withheld my hand, and for the sake of my name I did what would keep it from being profaned in the eyes of the nations in whose sight I had brought them out. Also with uplifted hand I swore to them in the wilderness that I would disperse them among the nations and scatter them through the countries, because they had not obeyed my laws but had rejected my decrees and desecrated my Sabbaths, and their eyes lusted after their parents’ idols. So I gave them other statutes that were not good and laws through which they could not live; I defiled them through their gifts—the sacrifice of every firstborn—that I might fill them with horror so they would know that I am the Lord.”**

God will let us go our own way because He doesn’t control us. He is a God of love and love requires freedom of choice.

Ezekiel 20:27–29, **“Therefore, son of man, speak to the people of Israel and say to them, “This is what the Sovereign**

Lord says: In this also your ancestors blasphemed me by being unfaithful to me: When I brought them into the land I had sworn to give them and they saw any high hill or any leafy tree, there they offered their sacrifices, made offerings that aroused my anger, presented their fragrant incense and poured out their drink offerings. Then I said to them: What is this high place you go to?" ' (It is called Bamah to this day.)"

The Lord is saying, "They made me sick."

Ezekiel 20:30–38, "Therefore say to the Israelites: "This is what the Sovereign Lord says: Will you defile yourselves the way your ancestors did and lust after their vile images? When you offer your gifts—the sacrifice of your children in the fire—you continue to defile yourselves with all your idols to this day. Am I to let you inquire of me, you Israelites? As surely as I live, declares the Sovereign Lord, I will not let you inquire of me. 'You say, "We want to be like the nations, like the peoples of the world, who serve wood and stone." But what you have in mind will never happen. As surely as I live, declares the Sovereign Lord, I will reign over you with a mighty hand and an outstretched arm and with outpoured wrath. I will bring you from the nations and gather you from the countries where you have been scattered—with a mighty hand and an outstretched arm and with outpoured wrath. I will bring you into the wilderness of the nations and there, face to face, I will execute judgment upon you. As I judged your ancestors in the wilderness of the land of Egypt, so I will judge you, declares the Sovereign Lord. I will take note of you as you pass under my rod, and I will bring you into the bond of the covenant. I will purge you of those who revolt and rebel against me. Although I will bring them out of the land where they are living, yet they will not enter the land of Israel. Then you will know that I am the Lord.'"

God had a remnant in Jerusalem, many of whom were practicing idolatry, and yet were still inquiring of the Lord. But

the Lord told Ezekiel, “I’m not talking to that group, they’re idolaters. I have nothing to say to them. Tell them I said so. I am however going to bring an end to the sin problem with or without their cooperation. I will send Messiah and establish everlasting righteousness.”

That is precisely what *Plan B* is. Israel would not repent of its rebellion, so God abandoned it, destroyed it, and then redefined Israel. Now, those called Israel are believers in Christ—the seed of Abraham. The time will come when the New Jerusalem will descend and rest on the same spot the old temple dwelled. And there in the Holy City, whose builder and maker is God, Abraham will be gathered to his children and live happily ever after. This is how God will resolve the sin problem.

\* \* \* \* \*

*Plan A* is outlined and described in the Old Testament. If Israel had cooperated with God and fulfilled their side of the bilateral covenant, Israel would have joyfully received Jesus as Messiah. All of the provisions and promises of *Plan A* would then have been fulfilled.

There would have been no New Testament. The Old Testament had it all and said it all. But Israel rebelled. Jesus was rejected and therefore the remainder of the provisions and promises of *Plan A* were abandoned. When it became evident that Christ would not be accepted while He was on earth, the plans changed—God put *Plan B* into effect. The New Testament describes the terms and conditions of *Plan B*. Yes, Daniel was written about the same time as Ezekiel, but Daniel was sealed up until the time of the end. God wanted *Plan A* to work and gave it every opportunity. That was His first choice. But when Israel refused Messiah, God switched to *Plan B*.

The question often arises: *If Israel would have accepted Jesus as Messiah how would He have died?* The Bible has the answer. At the appointed time in the middle of the 70th week, Jesus

would have been led to the Altar of Burnt Offering where the high priest would have pierced the body of Jesus with a knife. Notice the result of Him being pierced.

**Zechariah 12:10, “And I will pour out on the house of David and the inhabitants of Jerusalem a spirit of grace and supplication. They will look on me, the one they have pierced, and they will mourn for him as one mourns for an only child, and grieve bitterly for him as one grieves for a firstborn son.”**

The story of Abraham and Isaac on Mt. Moriah prefigured the death of Jesus. God asked Abraham to take his son Isaac to the top of Mt. Moriah and offer him as a sacrifice. This is a parallel of the Father giving up Jesus for our sins. God wanted one human being to understand and experience what He would do for our redemption. **“For God so loved the world that he gave his one and only Son, that whoever believes in him shall not perish but have eternal life.”** (John 3:16)

I understand from Scripture that the place Abraham built the altar on which to slay Isaac is where the Altar of Burnt Offering was located in Solomon’s temple. The place Isaac was to be slain is where Jesus would have been sacrificed in *Plan A*.

But because Israel rejected Christ, Jesus was slain outside the city on Calvary. Being crucified outside the city was the most profound way to express Jesus being separated from His own. The wicked in the book of Revelation are destroyed outside the New Jerusalem.

The following prophecy describes an attitude of sincere petitioning that would have taken place under *Plan A*—a time when the inhabitants of Jerusalem would be in great sorrow. **“On that day the weeping in Jerusalem will be as great as the weeping of Hadad Rimmon in the plain of Megiddo.”** (Zechariah 12:11)

I believe this verse is referring to a pagan ritual in which people would fast and mourn one of their gods. Now understand,

the Bible doesn't really offer any supporting information about it. I have come to this understanding from studying external material. In essence, the Lord is saying that "The nation of Israel will mourn for me like that."

**Zechariah 13:1–2, "On that day a fountain will be opened to the house of David and the inhabitants of Jerusalem, to cleanse them from sin and impurity. On that day, I will banish the names of the idols from the land, and they will be remembered no more,' declares the Lord Almighty. 'I will remove both the prophets and the spirit of impurity from the land.'"**

This is talking about what would have happened under *Plan A* had Israel been faithful. Jesus would have died and His death would have been most grievous for the whole nation. And on that day, a fountain would have opened to cleanse Israel from sin. If we understand how *Plan B* works, we can see the parallel.

Today, believers in Christ look at the cross with both sorrow and joy. Knowing Jesus had to die for our sins brings sorrow. But because He paid the price, the cross brings great joy. Isaiah 53:5 says, **"But he was pierced for our transgressions, he was crushed for our iniquities; the punishment that brought us peace was on him, and by his wounds we are healed."**

1 Peter 1:18–20, **"For you know that it was not with perishable things such as silver or gold that you were redeemed from the empty way of life handed down to you from your ancestors, but with the precious blood of Christ, a lamb without blemish or defect. He was chosen before the creation of the world, but was revealed in these last times for your sake."**

Jesus would have died under *Plan A* and Israel would have been heartbroken over His death. As a result, a fountain would have opened for the cleansing and removal of sin; then Israel would have been restored when they saw Him come forward from the tomb. But, this didn't happen. Israel rejected Messiah and instead of mourning over His death, rejoiced when



it happened. What does that say about our carnal nature and rebellion against God?

The length that God was willing to go to accomplish good for His children baffles me. But because of our rebellion, He resorts to *Plan B*. How many times in our life has God resorted to *Plan B* because we wouldn't cooperate? I have to remind myself that if I don't go forward in faith as the Spirit leads, God's optimal plan can't be realized.

Before moving forward, I want to expound on several points I made earlier.

Although *Plan A* had many events that were to occur, it was not put in chronological order in any of the Old Testament books as *Plan B* was in the books of Daniel and Revelation. It wasn't put in chronological order because Jesus would have been on earth during the time of its fulfillment. Jesus would have guided the people in understanding each fulfillment of *Plan A*, pointing to each event in Scripture as it took place.

When Jesus came to earth the first time—once He had set up His kingdom and died—He would have established the kingdom of God ushering in the everlasting righteousness predicted in Daniel 9.

**Ezekiel 20:33–38, “As surely as I live, declares the Sovereign Lord, I will reign over you with a mighty hand and an outstretched arm and with outpoured wrath. I will bring you from the nations and gather you from the countries where you have been scattered—with a mighty hand and an outstretched arm and with outpoured wrath. I will bring you into the wilderness of the nations and there, face to face, I will execute judgment upon you. As I judged your ancestors in the wilderness of the land of Egypt, so I will judge you, declares the Sovereign Lord. I will take note of you as you pass under my rod, and I will bring you into the bond of the covenant. I will purge you of those who revolt and rebel against me. Although I will bring them out of the land where they are living, yet they will not enter the land of**

**Israel. Then you will know that I am the Lord.”**

He is repeating Himself to make the point. God is going to pass over and judge everyone in Israel then purge those who can't be saved.

**Ezekiel 20:39–44, “As for you, people of Israel, this is what the Sovereign Lord says: Go and serve your idols, every one of you! But afterward you will surely listen to me and no longer profane my holy name with your gifts and idols. For on my holy mountain, the high mountain of Israel, declares the Sovereign Lord, there in the land all the people of Israel will serve me, and there I will accept them. There I will require your offerings and your choice gifts, along with all your holy sacrifices. I will accept you as fragrant incense when I bring you out from the nations and gather you from the countries where you have been scattered, and I will be proved holy through you in the sight of the nations. Then you will know that I am the Lord, when I bring you into the land of Israel, the land I had sworn with uplifted hand to give to your ancestors. There you will remember your conduct and all the actions by which you have defiled yourselves, and you will loathe yourselves for all the evil you have done. You will know that I am the Lord, when I deal with you for my name's sake and not according to your evil ways and your corrupt practices, you people of Israel, declares the Sovereign Lord.’”**

Many become confused when they read the Old Testament because they try to apply *Plan A* events to *Plan B* events at the end of the world. But the two plans do not mix. Everything God was going to do with the establishment of His kingdom on earth at the end of the 70 weeks is similar to that under *Plan B* at the second coming.

Wanting to understand the books of Isaiah, Ezekiel, and Jeremiah, many wonder when the described events will happen. Well, *Plan A* was abandoned and its events won't happen. God has abandoned much of what was written in the Old Testament

because He couldn't establish His kingdom at Christ's first coming.

The Old Testament's *Plan A* does not predict or offer a second coming. There was only going to be the first coming under *Plan A*. But Israel refused to accept Jesus as Messiah and *Plan B* was implemented. The two plans have many parallels and significant differences. For example: God was going to pass judgment on everyone in Israel; He was going to judge who would be kept or purged: a separating of the sheep and goats. We find this same parallel with the two witnesses in Revelation 11 but the timing is several thousand years apart.

We must understand the similarities and differences of the two plans to understand God's plan for us. The Old Testament is about *Plan A*, with the exception of the book of Daniel which God sealed up. When it became obvious that *Plan B* would have to be implemented, Daniel was unsealed for the end of time.



## chapter 7



# Israel's Apostasy

Ezekiel 36 is a review of Israel's apostasy. To understand the nation's downfall is to understand what happens in Chapters 37–39. Let's continue with Ezekiel 36.

Ezekiel 36:17–18, **“Son of man, when the people of Israel were living in their own land, they defiled it by their conduct and their actions. Their conduct was like a woman's monthly uncleanness in my sight. So I poured out my wrath on them because they had shed blood in the land and because they had defiled it with their idols.”** This was prior to Nebuchadnezzar's siege.

In Leviticus 18, God warned Israel what would happen if they defiled the land. **“Everyone who does any of these detestable things—such persons must be cut off from their people. Keep my requirements and do not follow any of the detestable customs that were practiced before you came and do not defile yourselves with them. I am the Lord your God.”** (Leviticus 18:29–30)

Back to Ezekiel, **“I dispersed them among the nations, and they were scattered through the countries; I judged them according to their conduct and their actions. [Not their words, not their statements of faith, but their conduct.] And wherever they went among the nations they profaned my holy name, for it was said of them, ‘These are the Lord’s people, and yet they had to leave his land.’”** (Ezekiel 36:19–20)

This was a taunt. God was aggravated with Israel and criticized their contempt for Him.

Ezekiel 36:21–22, **“I had concern for my holy name, which the people of Israel profaned among the nations where they had gone. Therefore say to the Israelites, ‘This is what the Sovereign Lord says: It is not for your sake, people of Israel, that I am going to do these things, but for the sake of my holy name, which you have profaned among the nations where you have gone.’”**

Israel was chosen to be a nation of Abrahams living among neighboring countries introducing them to the God of heaven. Instead, they tarnished and disgraced His holy name.

Ezekiel 36:23, **“I will show the holiness of my great name, which has been profaned among the nations, the name you have profaned among them. Then the nations will know that I am the Lord, declares the Sovereign Lord, when I am proved holy through you before their eyes.”** God was saying, “I am going to punish you because you have failed me. I want them to know who I am.”

Ezekiel 36:24–27, **”For I will take you out of the nations; I will gather you from all the countries and bring you back into your own land. I will sprinkle clean water on you, and you will be clean; I will cleanse you from all your impurities and from all your idols. I will give you a new heart and put a new spirit in you; I will remove from you your heart of stone and give you a heart of flesh. And I will put my Spirit in you and move you to follow my decrees and be careful to keep my laws.”** A new heart and a new spirit will come from

purification after the cleansing has taken place. This is equivalent to the sealing in *Plan B*.

Under *Plan A*, after Jesus had come to earth and died on the cross, He would have then brought about a miraculous change in Israel. He would judge the house of Israel as they passed under His rod. This is an expression that comes from tending sheep. As the sheep pass before a shepherd, he separates them into various pens with His rod. The idea in Ezekiel 36 is that Israel would pass under the Lord's rod and be judged. He would purge those in rebellion. Those He kept would be given a new heart and spirit, their carnal nature removed.<sup>1</sup>

It is miraculous how God removes the carnal nature. He *was* going to do it under *Plan A*, but *will* now do it under *Plan B*. Those who live the good fight of faith, He promises to cleanse from all impurities. Separation comes first, the purging of the wicked next, and then the sealing of God's saints. Afterwards, the Spirit will live within and guide all who keep His laws. Not in order to be saved, but because they are written in our heart and mind.

Ezekiel 36:28, **"Then you will live in the land I gave your ancestors; you will be my people, and I will be your God."** This was the promise to Abraham in Genesis 15. But at the point this takes place in the prophecy, it is no longer a bilateral covenant. When this happens after the sealing, the covenant becomes unilateral. The same promise is stated in Revelation at the end of the story. God says, "All who overcome will inherit all that was promised and I will be your God." Here is a parallel between *Plans A* and *B*.

Ezekiel 36:29–31, **"I will save you from all your uncleanness. I will call for the grain and make it plentiful and will not bring famine upon you. I will increase the fruit of the trees and the crops of the field, so that you will no longer suffer disgrace among the nations because of famine. Then**

---

<sup>1</sup> To understand the sealing, read Chapter 6 of my book "Jesus, the Alpha and Omega." [https://wake-up.org/Alpha/JesusA\\_O.pdf](https://wake-up.org/Alpha/JesusA_O.pdf)

**you will remember your evil ways and wicked deeds, and you will loathe yourselves for your sins and detestable practices.”**

This means, “How could we have treated the Lord this way?”

Ezekiel 36:32–35, **“I want you to know that I am not doing this for your sake, declares the Sovereign Lord. Be ashamed and disgraced for your conduct, people of Israel! This is what the Sovereign Lord says: ‘On the day I cleanse you from all your sins, I will resettle your towns, and the ruins will be rebuilt.’ The desolate land will be cultivated instead of lying desolate in the sight of all who pass through it. They will say, ‘This land that was laid waste has become like the garden of Eden; the cities that were lying in ruins, desolate and destroyed, are now fortified and inhabited.’”** For whom this is being done is important.

Under *Plan A*, Jesus would have set up the kingdom of God in Jerusalem, purged Israel of the rebellious, then sealed His servants. The surrounding nations would have seen these events (a great transformation) take place. The desert would have bloomed into a new Garden of Eden, and the destroyed cities rebuilt even better than before. Jesus would have then sent the twelve tribes out into the world to gather all who wanted to be saved. Each heart would have been changed, the carnal nature removed, and righteousness sealed inside forevermore.

Zechariah 8 describes it this way, **“‘And many peoples and powerful nations will come to Jerusalem to seek the Lord Almighty and to entreat him.’ This is what the Lord Almighty says: ‘In those days ten people from all languages and nations will take firm hold of one Jew by the hem of his robe and say, “Let us go with you, because we have heard that God is with you.”’”** (Zechariah 8:22–23)

The Bible tells us that people would come from all nations to worship the Lord in His temple. This was *Plan A*, and God was going to use Israel to accomplish this. Under *Plan B*, God will do the same using a very different Israel.



Ezekiel 36:36, **“Then the nations around you that remain will know that I the Lord have rebuilt what was destroyed and have replanted what was desolate. I the Lord have spoken, and I will do it.”** What the majority of Israel didn't conceive was that He planned to accomplish this at the end of the 70 weeks, which ended in AD 33.

Ezekiel 36:37–38, **“This is what the Sovereign Lord says: Once again I will yield to Israel's plea and do this for them: I will make their people as numerous as sheep, as numerous as the flocks for offerings at Jerusalem during her appointed festivals. So will the ruined cities be filled with flocks of people. Then they will know that I am the Lord.”** These people were to come from surrounding nations. All who were sincere in heart would pour into the city of Jerusalem, become part of Israel, and be God's people. This was *Plan A*.

Believers have always been reckoned as those who believe in God—even under *Plan A*. God has people in every tribe, language, and nation. They hear His voice and allow the Holy Spirit dominion in their heart. *Plan A* was to bring the nations together into Jerusalem. After a period of mercy was extended to the whole world, God would bring the Devil and his angels against Jerusalem. Then, after resolving the sin problem, Jesus would destroy Lucifer and all the wicked.

Under *Plan B*, it will be the same. After the Holy City descends, God will resurrect the wicked who quickly surround the city and assail it with Satan leading the charge. God then sends fire down and burns them up.

\* \* \* \* \*

Ezekiel 37:1, **“The hand of the Lord was on me, and he brought me out by the Spirit of the Lord and set me in the middle of a valley; it was full of bones.”**

This describes the destruction and slaughter of Israel by Nebuchadnezzar. In ancient times slain troops were not buried, they were left where they fell. Scavengers would gorge

themselves. What remained, rotted. The Lord took Ezekiel in a vision to see this happen.

**Ezekiel 37:2, “He led me back and forth among them, and I saw a great many bones on the floor of the valley, bones that were very dry.”**

The flesh had been eaten by fowl, vermin, and animals—the bones bleached by the sun. These are the bones of soldiers who fought against King Nebuchadnezzar. And the fact they are dry means some time had passed.

**Ezekiel 37:3–6, “He asked me, ‘Son of man, can these bones live?’ I said, ‘Sovereign Lord, you alone know.’ Then he said to me, ‘Prophecy to these bones and say to them, “Dry bones, hear the word of the Lord! This is what the Sovereign Lord says to these bones: I will make breath enter you, and you will come to life. I will attach tendons to you and make flesh come upon you and cover you with skin; I will put breath in you, and you will come to life. Then you will know that I am the Lord.”’”** This was an allusion to the forthcoming resurrection.

**Ezekiel 37:7–9, “So I prophesied as I was commanded. And as I was prophesying, there was a noise, a rattling sound, and the bones came together, bone to bone. I looked, and tendons and flesh appeared on them and skin covered them, but there was no breath in them. Then he said to me, ‘Prophecy to the breath; prophecy, son of man, and say to it, “This is what the Sovereign Lord says: Come, breath, from the four winds and breathe into these slain, that they may live.”’”**

**Ezekiel 37:10–11, “So I prophesied as he commanded me, and breath entered them; they came to life and stood up on their feet—a vast army. Then he said to me: ‘Son of man, these bones are the people of Israel. They say, “Our bones are dried up and our hope is gone; we are cut off.”’”**

**Ezekiel 37:12–14, “Therefore prophecy and say to them:**

**‘This is what the Sovereign Lord says: My people, I am going to open your graves and bring you up from them; I will bring you back to the land of Israel. Then you, my people, will know that I am the Lord, when I open your graves and bring you up from them. I will put my Spirit in you and you will live, and I will settle you in your own land. Then you will know that I the Lord have spoken, and I have done it, declares the Lord.’**”

Under *Plan A*, there was to be a resurrection of the righteous and the wicked. This will also happen under *Plan B*, after which, the righteous will live happily ever after with the Lord. And that’s what this story is all about! Today, the story is corrupted to align with what people want to believe. In *Plan A*, God wanted to bring about eternal life on earth at the end of the 70 weeks (Daniel 9:24). He wanted to establish His kingdom at that time. But it didn’t happen. It will happen under *Plan B*.

Ezekiel 37:15–16, **“The word of the Lord came to me: ‘Son of man, take a stick of wood and write on it, “Belonging to Judah and the Israelites associated with him.” Then take another stick of wood, and write on it, “Belonging to Joseph (that is, to Ephraim) and all the Israelites associated with him.”’”** Judah refers to the southern two tribes, and Ephraim the northern ten tribes.

Ezekiel 37:17–19, **“Join them together into one stick so that they will become one in your hand. When your people ask you, ‘Won’t you tell us what you mean by this?’ say to them, ‘This is what the Sovereign Lord says: I am going to take the stick of Joseph—which is in Ephraim’s hand—and of the Israelite tribes associated with him, and join it to Judah’s stick. I will make them into a single stick of wood, and they will become one in my hand.’”**

The shepherd’s rod and staff were symbols of love and caring. They were used to rescue and discipline. In Psalm 23, David acknowledged that God’s rod and staff brought comfort

to him.

When Solomon died, the kingdom of Israel was broken into two parts. The northern tribes separated from the southern tribes over a dispute of who would be king. Solomon's son Rehoboam became ruler over the two southern tribes, and Jeroboam became ruler over the ten northern tribes. The two kingdoms didn't like each other and the hostility turned into civil war.

In 722 bc, Shalmaneser V destroyed the north and scattered its tribes. About a hundred years later, Nebuchadnezzar began destroying Judah in the south. At the time, Israel's remnant was tiny. In this vision, the Lord showed Ezekiel what He had planned. Ezekiel demonstrated this to the elders. By joining the two sticks, God was indicating that He was going to make one nation again.

**Ezekiel 37:20–22, “Hold before their eyes the sticks you have written on and say to them, ‘This is what the Sovereign Lord says: I will take the Israelites out of the nations where they have gone. I will gather them from all around and bring them back into their own land. I will make them one nation in the land, on the mountains of Israel. There will be one king over all of them and they will never again be two nations or be divided into two kingdoms.’”** There would no longer be two nations—Israel would be whole again.

**Ezekiel 37:23–24, “They will no longer defile themselves with their idols and vile images or with any of their offenses, for I will save them from all their sinful backsliding, and I will cleanse them. They will be my people, and I will be their God. My servant David will be king over them, and they will all have one shepherd. They will follow my laws and be careful to keep my decrees.”**

This cleansing would have only happened after Jesus was pierced. King David was going to be resurrected under *Plan A* to rule as king under the authority of Christ—a prince if you will.

Ezekiel 37:25–26, “They will live in the land I gave to my servant Jacob, the land where your ancestors lived. They and their children and their children’s children will live there forever, and David my servant will be their prince forever. I will make a covenant of peace with them; it will be an everlasting covenant. I will establish them and increase their numbers, and I will put my sanctuary among them forever.”

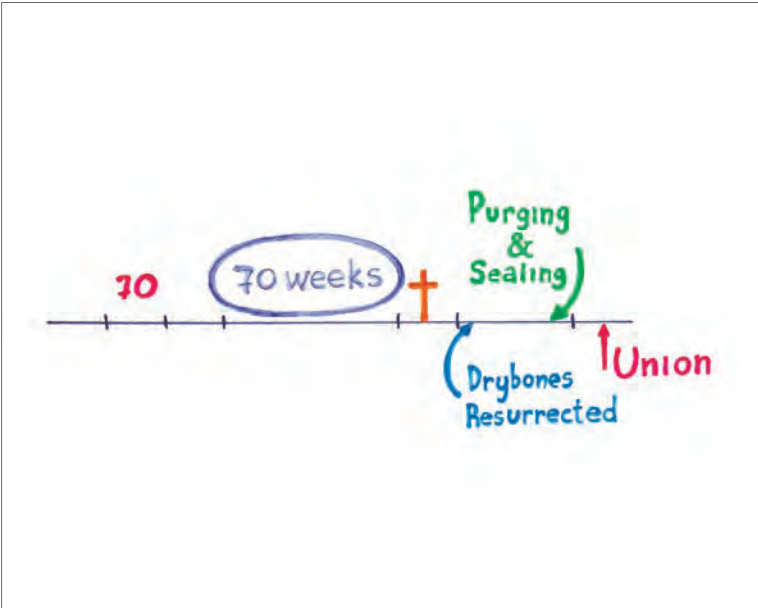

Drawing 7.1

Let's review in drawing 7.1 the chronology of what God had planned. Israel was to be remanded to Babylon for 70 years. Afterwards God would bring them out and establish them back in their homeland. They would then be given 490 years (70 weeks) of probationary time to begin cooperating with God. In the middle of the 70th week, Messiah was to come and die (cross). Having been sacrificed (pierced), Jesus would have purged and sealed Israel. The righteous would be resurrected, David placed on his throne, and the twelve tribes reunified.

The verses are describing how *Plan A* would have unfolded

The big problem today is that most theologians and prophecy experts want Ezekiel's prophecies to apply to the modern Israel established in 1948. This is nonsense.

Ezekiel's prophecies are about the Lord establishing His kingdom on earth at the end of the 70 weeks which ended in ad 33. The kingdom of God was to be established when Jesus came the first time. Both John the Baptist and Daniel confirm this.

Under *Plan A*, the events in Ezekiel would have happened. Under *Plan B*, events won't playing out the same. Under *Plan B*, Christ will come, gather the saints and take them to heaven. That's why Paul says the saints will meet the Lord in the air. Jesus will not set up His kingdom on earth until it has been purified, which doesn't happen until after the one thousand years of Revelation 20. The Devil will appear masquerading as God who has come to set up his kingdom on earth. Unfortunately, many will believe him. People will buy into his sophism. We need to study the Bible so we know what God has planned.

**Ezekiel 37:27–28, “My dwelling place will be with them; I will be their God, and they will be my people. Then the nations will know that I the Lord make Israel holy, when my sanctuary is among them forever.”**

This is exactly what Lucifer will claim when he appears. He will claim to be God—fulfilling what many people expect. The reason the Lord destroyed Israel's temple in ad 70 was because He will never use it again. He will not place His sanctuary in Jerusalem until the earth has been cleansed. This is described in the book of Revelation.

\* \* \* \* \*

**Ezekiel 38:1–3, “The word of the Lord came to me: ‘Son of man, set your face against Gog, of the land of Magog, the chief prince of Meshek and Tubal; prophesy against him and say: “This is what the Sovereign Lord says: I am against you, Gog, chief prince of Meshek and Tubal.” ’ ”**

Gog didn't exist in Ezekiel's day. The king would only appear many years after Ezekiel died. I believe the name Gog, a synonym of God, is a clue to who he really is: Lucifer the Antichrist. At an appointed time, Gog, the chief prince, would destroy Jerusalem. Lucifer is the one that God was going to bring against Jerusalem in *Plan A* so that He might destroy him along with the wicked. The same will happen under *Plan B* but will play out differently. Gog is the same being with a different identity.

**Ezekiel 38:4–6, “I will turn you around, put hooks in your jaws and bring you out with your whole army—your horses, your horsemen fully armed, and a great horde with large and small shields, all of them brandishing their swords. Persia, Cush and Put will be with them, all with shields and helmets, also Gomer with all its troops, and Beth Togarmah from the far north with all its troops—the many nations with you.”**

Cush and Put were part of Egypt—what today are known as Ethiopia and Libya. Gog was going to be brought against God's people. The term *hooks in the jaws* refers to the way prisoners were transported. When a large number of prisoners were moved, captors would put a large fishhook through a jaw of each prisoner, then run a string through the eyelets of the hooks. Using this technique, one man could control many prisoners.

**Ezekiel 38:7–9, “Get ready; be prepared, you and all the hordes gathered about you, and take command of them. After many days you will be called to arms. In future years you will invade a land that has recovered from war, whose people were gathered from many nations to the mountains of Israel, which had long been desolate. They had been brought out from the nations, and now all of them live in safety. You and all your troops and the many nations with you will go up, advancing like a storm; you will be like a cloud covering the land.”**

At this time, the purging and sealing were to have taken place, with the wicked surrounding the city and the redeemed inside. It happens the same way in *Plan B*.

Verses 10–11, **“This is what the Sovereign Lord says: On that day thoughts will come into your mind and you will devise an evil scheme. You will say, ‘I will invade a land of unwalled villages; I will attack a peaceful and unsuspecting people—all of them living without walls and without gates and bars.’** The cities would be without walls and bars (locks) because the people wouldn’t have sinful natures.

Ezekiel 38:12–16, **“ ‘I will plunder and loot and turn my hand against the resettled ruins and the people gathered from the nations, rich in livestock and goods, living at the center of the land.’ Sheba and Dedan and the merchants of Tarshish and all her villages will say to you, ‘Have you come to plunder? Have you gathered your hordes to loot, to carry off silver and gold, to take away livestock and goods and to seize much plunder?’”**

**“Therefore, son of man, prophesy and say to Gog: ‘This is what the Sovereign Lord says: In that day, when my people Israel are living in safety, will you not take notice of it? You will come from your place in the far north, you and many nations with you, all of them riding on horses, a great horde, a mighty army. You will advance against my people Israel like a cloud that covers the land. In days to come, Gog, I will bring you against my land, so that the nations may know me when I am proved holy through you before their eyes.’”**

This was how the world would have been purified of sin and sinners under *Plan A*. It is how the world will be purified of sin and sinners under *Plan B*.

Ezekiel 38:17, **“This is what the Sovereign Lord says: You are the one I spoke of in former days by my servants the prophets of Israel. At that time they prophesied for years that I would bring you against them.”**



This was referring to Gog who is also mentioned in Isaiah 14, which was written about a hundred years earlier.

Isaiah 14:12–17, **“How you have fallen from heaven, morning star, son of the dawn! You have been cast down to the earth, you who once laid low the nations! You said in your heart, ‘I will ascend to the heavens; I will raise my throne above the stars of God; I will sit enthroned on the mount of assembly, on the utmost heights of Mount Zaphon. I will ascend above the tops of the clouds; I will make myself like the Most High.’**

But you are brought down to the realm of the dead, to the depths of the pit. Those who see you stare at you, they ponder your fate: ‘Is this the man who shook the earth and made kingdoms tremble, the man who made the world a wilderness, who overthrew its cities and would not let his captives go home?’” Lucifer was called Gog for the first time in Ezekiel.

Ezekiel 38:18–19, **“This is what will happen in that day: When Gog attacks the land of Israel, my hot anger will be aroused, declares the Sovereign Lord. In my zeal and fiery wrath I declare that at that time there shall be a great earthquake in the land of Israel.”**

This earthquake has a parallel in *Plan B*. It is described in Revelation 16. **“Then there came flashes of lightning, rumblings, peals of thunder and a severe earthquake. No earthquake like it has ever occurred since mankind has been on earth, so tremendous was the quake. The great city split into three parts, and the cities of the nations collapsed. God remembered Babylon the Great and gave her the cup filled with the wine of the fury of his wrath. Every island fled away and the mountains could not be found.”** (Revelation 16:18–20) This happens at the second coming.

The word *rumblings* comes from a Greek word that indicates *voices* will be heard. It is translated *voices* in the King James Version because it is describing words being spoken. Notice

the sequence of events. This is not symbolic—it is literal.

Consider verses 20–21 this way: **“Every [literal] island fled away and the [literal] mountains could not be found. From the [literal] sky huge [literal] hailstones, each weighing about a hundred pounds, fell on [literal] people. And they [literally] cursed God on account of the [literal] plague of hail, because the plague was so [literally] terrible.”**

Why would anyone believe this is symbolic? What would a symbolic earthquake or flash of lightning represent? The Bible is being literal. What is said makes perfect sense just as it reads. The idea that Revelation is all symbolic is nonsense. There are pieces that are symbolic but the Bible defines what those symbols mean.

Let’s continue with Ezekiel 38:20. **“The fish in the sea, the birds in the sky, the beasts of the field, every creature that moves along the ground, and all the people on the face of the earth will tremble at my presence. The mountains will be overturned, the cliffs will crumble and every wall will fall to the ground.”** Although this is *Plan A*, it sounds very much like the second coming in Revelation.

After the Lord had begun the process of setting up His kingdom on earth in *Plan A*, Gog would have attacked Jerusalem but the Lord would have destroyed him. Following would have been a great earthquake and the mountains moved out of their places.

Ezekiel 38:21, **“I will summon a sword against Gog on all my mountains, declares the Sovereign Lord. Every man’s sword will be against his brother.”** This describes God sending a spirit of confusion upon the armies of Gog who turn on each other.

Ezekiel 38:22, **“I will execute judgment on him with plague and bloodshed; I will pour down torrents of rain, hailstones and burning sulfur on him and on his troops and on the many nations with him.”** This was not talking about

rain made of water, this was fire. Under *Plan B*, when Satan and his armies attack God's people after the thousand years, God sends hailstones and burning sulfur to kill them.

Revelation 20:7–9, **“When the thousand years are over, Satan will be released from his prison and will go out to deceive the nations in the four corners of the earth—Gog and Magog—and to gather them for battle. In number they are like the sand on the seashore. They marched across the breadth of the earth and surrounded the camp of God's people, the city he loves. But fire came down from heaven and devoured them.”**

Satan was put into the spirit-world prison wearing a big chain. During the thousand years, Lucifer is locked down with no one to tempt. Evil can do no more damage. As he is contemplating his fate, the saints are in heaven determining the sentences of the wicked. At the end of millennium, Lucifer will be released from his prison to deceive the nations. The Holy City descends and the wicked are resurrected.

In Revelation, John simply used the names Gog and Maygog to refer back to Ezekiel. He wants us to understand that what was predicted in Ezekiel will not come to pass. However, *Plan B* will accomplish what *Plan A* was meant to.

Ezekiel 38:23, **“And so I will show my greatness and my holiness, and I will make myself known in the sight of many nations. Then they will know that I am the Lord.”** This is the same as *Plan B*, except it was to happen under *Plan A*. God's original plan was for Israel to enter the Promised Land two years after leaving Egypt. But when the leaders of each tribe were sent in to spy out the land, only two of the twelve gave a faithful report. This made the Lord angry. Their history with Him was a complete disaster.

I'm not picking on Israel, the story would have been the same for any nation. The Old Testament is not so much a story of how bad Israel was, but how rebellious our human nature really is. We are all like Israel. Any other nation would have

done the same thing.

So how is it with you and the Lord? Is God's *Plan A* for your life working? Are you allowing the Lord to have His way in your life? Are you willing to go, be, and do all that He asks? If not, you're forcing God to use a *Plan B*, *C*, or even *D*. Surrender your will to Him and see what He will do in your life! When you have that personal experience with the Lord you are living by faith, and those who live by faith are justified.

Messages in the book of Ezekiel parallel the end time, although the book has nothing to do with *Plan B*. This is why it is important to understand Ezekiel. God is going to use the rebellion, ignorance, and foolishness of the wicked to reveal Himself to all nations. I am puzzled by the number of times the statement, "**Then they will know that I am the Lord**" is used. It is repetitiously repeated because people don't realize who God is. There is no fear or awe of God because He doesn't show Himself overtly. That will soon change. And when it does, the whole world will unmistakably *know* who He is.

I have done my best to establish that *Plan A* and *Plan B* accomplish the same objective but at a different time. *Plan A* called for the destruction of Gog and the wicked as they attacked *Jerusalem*. *Plan B* calls for the destruction of Lucifer (who is Gog) and the wicked as they attack the *New Jerusalem*.

As we familiarize ourselves with what was to happen in *Plan A*, the better we comprehend what will happen in *Plan B*. The beauty of *Plan B* can be seen when you understand *Plan A*, but God doesn't explain *Plan B* as extensively as He did *Plan A*. So keep the two plans separate and distinct from each other.

I marvel at God because anytime something goes wrong, He always brings something better out of the disaster. That's why it is imperative we trust Him. When we serve God and live by faith, bad things will happen, you can count on it—the Devil will see to it. But as we look back over our lives at the difficult moments, we see the Lord is faithful.

## chapter 8



# Temple Services

Had *Plan A* been implemented, God's people, after studying Ezekiel, would have clearly understood how the end of the world would culminate. Several chapters in Ezekiel are dedicated to this because God wants us, today, to understand how *Plan B* will occur. Let's begin this last chapter with Ezekiel 39. Please follow along in your Bible.

Ezekiel 39:1, **“Son of man, prophesy against Gog and say: ‘This is what the Sovereign Lord says: I am against you, Gog, chief prince of Meshek and Tubal.’”**

Lucifer is the prince of this world. Meshek and Tubal are two nations north of Israel.

Ezekiel 39:2, **“I will turn you around and drag you along. I will bring you from the far north and send you against the mountains of Israel.”**

This is being done against their will.

The north is significant because it is from where divine judgments originate. In Jeremiah 25, Nebuchadnezzar comes

out of the north when God sends him against Israel. And at the end, the Devil comes from the north to attack the Holy City but will be destroyed.

**Ezekiel 39:3–5, “Then I will strike your bow from your left hand and make your arrows drop from your right hand. On the mountains of Israel you will fall, you and all your troops and the nations with you. I will give you as food to all kinds of carrion birds and to the wild animals. You will fall in the open field, for I have spoken, declares the Sovereign Lord.”**

This is also described in Revelation 19:17–18. **“And I saw an angel standing in the sun, who cried in a loud voice to all the birds flying in midair, ‘Come, gather together for the great supper of God, so that you may eat the flesh of kings, generals, and the mighty, of horses and their riders, and the flesh of all people, free and slave, great and small.’”**

John saw an angel summon all scavenger birds to gorge themselves. I do the same at potlucks...and so do you!

**Ezekiel 39:6–8, “I will send fire on Magog and on those who live in safety in the coastlands, and they will know that I am the Lord. I will make known my holy name among my people Israel. I will no longer let my holy name be profaned, and the nations will know that I the Lord am the Holy One in Israel. It is coming! It will surely take place, declares the Sovereign Lord. This is the day I have spoken of.”**

This didn't happen under *Plan A* but surely will in *Plan B*.

**Ezekiel 39:9–10, “Then those who live in the towns of Israel will go out and use the weapons for fuel and burn them up—the small and large shields, the bows and arrows, the war clubs and spears. For seven years they will use them for fuel. They will not need to gather wood from the fields or cut it from the forests, because they will use the weapons for fuel. And they will plunder those who plundered them and loot those who looted them, declares the Sovereign Lord.”**

That is an enormous amount of weapons! Under *Plan A*, judicial equilibrium was to have been rendered. “As you do unto others, it will be done unto you.” The principle was clearly stated.

**Ezekiel 39:11, “On that day I will give Gog a burial place in Israel, in the valley of those who travel east of the Sea. It will block the way of travelers, because Gog and all his hordes will be buried there. So it will be called the Valley of Hamon Gog.”**

The burial ground would be so large travel would be rerouted like a beltway around a city.

**Ezekiel 39:12–20, “For seven months the Israelites will be burying them in order to cleanse the land. All the people of the land will bury them, and the day I display my glory will be a memorable day for them, declares the Sovereign Lord. People will be continually employed in cleansing the land. They will spread out across the land and, along with others, they will bury any bodies that are lying on the ground. After the seven months they will carry out a more detailed search. As they go through the land, anyone who sees a human bone will leave a marker beside it until the gravediggers bury it in the Valley of Hamon Gog, near a town called Hamonah. And so they will cleanse the land.’ Son of man, this is what the Sovereign Lord says: Call out to every kind of bird and all the wild animals: ‘Assemble and come together from all around to the sacrifice I am preparing for you, the great sacrifice on the mountains of Israel. There you will eat flesh and drink blood. You will eat the flesh of mighty men and drink the blood of the princes of the earth as if they were rams and lambs, goats and bulls—all of them fattened animals from Bashan. At the sacrifice I am preparing for you, you will eat fat till you are glutted and drink blood till you are drunk. At my table you will eat your fill of horses and riders, mighty men and soldiers of every kind,’ declares the Sovereign Lord.”**

Ezekiel was showing what would have happened in *Plan A* at the end of the 70 weeks, not the end of the world. This is why the book of Ezekiel is confusing today. The difference in timing confuses those who lift verses out of *Plan A* and apply them to the end of the world.

**Ezekiel 39:21–27, “I will display my glory among the nations, and all the nations will see the punishment I inflict and the hand I lay on them. From that day forward the people of Israel will know that I am the Lord their God. And the nations will know that the people of Israel went into exile for their sin, because they were unfaithful to me. So I hid my face from them and handed them over to their enemies, and they all fell by the sword. I dealt with them according to their uncleanness and their offenses, and I hid my face from them. Therefore this is what the Sovereign Lord says: I will now restore the fortunes of Jacob and will have compassion on all the people of Israel, and I will be zealous for my holy name. They will forget their shame and all the unfaithfulness they showed toward me when they lived in safety in their land with no one to make them afraid. When I have brought them back from the nations and have gathered them from the countries of their enemies, I will be proved holy through them in the sight of many nations.”**

God had a rebellious nation on His hands, so He punished them by sending them into captivity. His plan was to then restore them to their land. If they would allow the Spirit to live within, He would remove their shame and reveal Himself to other nations through them. But on Israel’s return from Babylon, they rejected Messiah. So God redefined Israel. Now, all who believe in Christ are heirs of Abraham. Read about this in Galatians 3, Ephesians 2, and Romans 9–11.

**Ezekiel 39:28–29, “Then they will know that I am the Lord their God, for though I sent them into exile among the nations, I will gather them to their own land, not leaving any behind. I will no longer hide my face from them, for I**



**will pour out my Spirit on the people of Israel, declares the Sovereign Lord.”**

The outpouring of the Holy Spirit is our great need—it is the key. And if we allow God to have His way in our lives, we must receive the Spirit. The Bible teaches there is only one unpardonable sin—rejecting the Holy Spirit. (Matthew 12) Rejecting Him is easy because we are predisposed to rebellion just like Israel.

At the second coming, one-third of the living will be translated, and two-thirds destroyed because they will have committed the unpardonable sin. God lost one-third of the angels because they chose to rebel against the Spirit. So how was God to reach them?

The angels weren't initially encumbered with rebellious natures; they willfully chose to reject the Holy Spirit. God will replace those fallen angels with the redeemed of earth so His house will be whole once again. He will repopulate heaven with human beings who are born with a rebellious nature, yet choose submission to the Spirit. They will replace the angels who had sinless natures but chose to rebel. Let that sink in! I believe the number of angels that were thrown out of heaven will be replaced with the same number of humans who fight against their rebellious natures and are redeemed.

\* \* \* \* \*

The vision of Ezekiel 40 took place in 573 bc. This was about fourteen years after Nebuchadnezzar besieged Jerusalem for the third and final time in 586 bc. The year of Jerusalem's siege has been validated. It is a secure date.

In the vision were plans for a new temple which was to be built where the old temple stood. Under *Plan A*, God was going to restore His people from the nations from which He had scattered them. Four decrees were given to facilitate the restoration of Israel to their homeland and the rebuilding of the temple.

The temple the Lord wanted built was magnificent! When Zerubbabel looked at what Ezekiel had written, he was overwhelmed by the architectural plans. He knew the returning refugees didn't have the skilled labor to perform the work and were too poor to afford the materials required to build such a structure.

God would have enabled this temple to be erected, just like He enabled the construction of Solomon's temple, had Israel been faithful. He had sent the message: **"This is the word of the Lord to Zerubbabel: 'Not by might nor by power, but by my Spirit,' says the Lord Almighty."** (Zechariah 4:6)

But the temple envisioned was never built. That should have been their first clue something was terribly wrong.

Ezekiel 40:1–3, **"In the twenty-fifth year of our exile, at the beginning of the year, on the tenth of the month, in the fourteenth year after the fall of the city—on that very day the hand of the Lord was on me and he took me there. In visions of God he took me to the land of Israel and set me on a very high mountain, on whose south side were some buildings that looked like a city. He took me there, and I saw a man whose appearance was like bronze; he was standing in the gateway with a linen cord and a measuring rod in his hand."**

This glowing man was holding a tape measure.

Ezekiel 40:4–5, **"The man said to me, 'Son of man, look carefully and listen closely and pay attention to everything I am going to show you, for that is why you have been brought here. Tell the people of Israel everything you see.' I saw a wall completely surrounding the temple area. The length of the measuring rod in the man's hand was six long cubits, each of which was a cubit and a handbreadth. He measured the wall; it was one measuring rod thick and one rod high."**

This was about 9 feet tall and 9 feet thick.

Ezekiel was receiving all of these measurements because

he was to be the conduit God used to describe how the new temple was to be built under *Plan A*. Ezekiel was to this temple what Moses was to the tabernacle in the wilderness. God was very particular about the construction of His temple because its services contained important lessons Israel needed to learn and we today need to know. Let me explain.

Suppose you are of average intelligence, yet know nothing about the game of chess, and enter a room where two people are playing the game. If you were to sit and watch them play long enough, you would be able to figure out its rules: how the game is played, how each piece moves, and what it takes to win. You learn by observation.

This is an analogy of the way services worked in the temple. I mentioned this at the beginning of my book because we have to understand the significance of the lessons God was trying to teach. By studying Him in His temple, we can understand the issues of the Plan of Salvation. By watching how the priests served—what they were told to do and what they were allowed to do—we begin to understand the terms and conditions of salvation.

That's why God told Moses, "When you make the tabernacle, see to it that the exact pattern I gave you is followed." It was because for centuries to come, men would study this temple to understand God's ways. In fact, that's how I test all of my views about salvation and the plan for implementing it. This is where I learned about restitution and the disposition and transference of sin. All that concerns salvation's plan is seen in the sanctuary services. This is why it was so crucial for it to be built exactly as shown and that the priests performed their tasks as instructed.

The tasks did not have efficacy of themselves. They didn't actually do what they represented. For example: When the priest slayed a lamb and put blood on the four horns, they weren't really transferring sin away from an individual. They were only portraying how sin is transferred through the blood

of Jesus (the Lamb of God) to the altar in heaven. The priest didn't have the ability, power, or authority to transfer sin or forgive the sinner; he was only there to make sure the lamb had no blemish and that the proper procedure was followed.

This is crystal clear in the Book of Hebrews which says, "The blood of goats and bulls never cleansed anybody of sin." (Hebrews 10:4) What the priests did and how they went about it was the issue. This was why God insisted His temple be built so carefully. All of its measurements, numbers, timing, and procedures were critical. Each exposes something about God and His ways. Ezekiel 41 and 42 detail the dimensions—its blueprint if you will.

Jump over to Ezekiel 43:1–6. **"Then the man brought me to the gate facing east, and I saw the glory of the God of Israel coming from the east. His [Jesus] voice was like the roar of rushing waters, and the land was radiant with his glory. The vision I saw was like the vision I had seen when he came to destroy the city and like the visions I had seen by the Kebar River, and I fell facedown. The glory of the Lord entered the temple through the gate facing east. Then the Spirit lifted me up and brought me into the inner court, and the glory of the Lord filled the temple. While the man was standing beside me, I heard someone speaking to me from inside the temple."**

This is Jesus.

Ezekiel 43:7, **"He said: 'Son of man, this is the place of my throne and the place for the soles of my feet. This is where I will live among the Israelites forever. The people of Israel will never again defile my holy name—neither they nor their kings—by their prostitution and the funeral offerings for their kings at their death.'"**

A time was coming when sin would be no more.

Ezekiel 43:8, **"When they placed their threshold next to my threshold and their doorposts beside my doorposts,**

**with only a wall between me and them, they defiled my holy name by their detestable practices. So I destroyed them in my anger.”**

The temple Solomon built had many small chambers beside the sacred room where the Lord dwelled. Priests allowed idols to be placed and worshiped in these rooms. This is why He destroyed them and the temple.

**Ezekiel 43:9–12, “Now let them put away from me their prostitution and the funeral offerings for their kings, and I will live among them forever. Son of man, describe the temple to the people of Israel, that they may be ashamed of their sins. Let them consider its perfection, and if they are ashamed of all they have done, make known to them the design of the temple—its arrangement, its exits and entrances—its whole design and all its regulations and laws. Write these down before them so that they may be faithful to its design and follow all its regulations. This is the law of the temple: All the surrounding area on top of the mountain will be most holy. Such is the law of the temple.”**

The Lord was saying, “Let them watch, examine, and see how the game is played. They need to understand the significance of the services in my temple and be ashamed of what they have done. To understand the issues of salvation, we need to study His temple. There’s no other way to know.

That’s why the doctrine of parallel temples is so crucial. If we don’t understand it correctly, the prophecies of *Plan B* won’t make sense. The temple services on earth are a model of what is being done in heaven. Think of the sanctuary services as a miniature of *Plan A / Plan B*. Ezekiel 43:13–27 are more measurements and regulations.

Skip to Ezekiel 44:1. **“Then the man brought me back to the outer gate of the sanctuary, the one facing east, and it was shut. The Lord said to me, ‘This gate is to remain shut. It must not be opened; no one may enter through it. It is to remain shut because the Lord, the God of Israel, has entered**

through it.’” (Ezekiel 44:1-2)

The temple was oriented to face east.

Ezekiel 44:3, **“The prince (King David) himself is the only one who may sit inside the gateway to eat in the presence of the Lord. He is to enter by way of the portico of the gateway and go out the same way.”**

Remember, David was to be resurrected and serve as prince. And Jesus referred to this gateway when He told the disciples, “I am the way and no man comes to the Father except through me. I am the sheep gate.” (John 10)

Jump over to Ezekiel 48:29. **“This is the land you are to allot as an inheritance to the tribes of Israel, and these will be their portions,’ declares the Sovereign Lord.”**

In Chapter 48, the gates of the city were named after the twelve tribes. Its north side was the powerful side. The name of the city was going to be changed from Jerusalem to *The Lord is There*. Read Chapter 48 in your Bible and see the plans God had for this magnificent city.

\* \* \* \* \*

Although this book isn’t an exhaustive study of the Book of Ezekiel, I hope it has been interesting enough to grasp what God was telling Ezekiel about *Plan A*. In closing, as a review, I offer ten conclusions found in Ezekiel.

(1) God’s patience came to an end because of apostasy. When Israel filled up its cup of iniquity, God sent a destroyer to punish them. This is how He deals with all nations. God’s patience with the world will come to an end. Revelation 9 describes a destroyer set upon the earth such as was sent upon Israel.

(2) God’s four deadly judgments: sword, famine, plague, and wild beasts are literal. I discussed how these were imposed upon Jerusalem, and they are coming again to be imposed on the earth as a whole. These same four judgments mark the beginning of the great tribulation.

(3) God spared one-third as a remnant.

(4) God's patience with Israel lasted seventy Sabbath years. The parallel is that God's patience with the world and sin comes to an end at the conclusion of seventy centuries. After the thousand years of Revelation 20, sin will forever more be destroyed.

(5) God promised the Israelites restoration in the fulfillment of *Plan A* but they didn't adhere to the conditions or listen to the Spirit. Therefore, Jerusalem was destroyed forever in ad 70. I say forever with respect to Israel as a nation of people belonging to God. God redefined Israel and today's Israel is scattered over the world. Now God's Israel refers to those who listen to the Spirit, have a born-again experience, and allow Him to change their heart.

(6) God showed how He would separate the pure in heart, purge Israel, and end sin.

(7) God provided the reasons why He destroys the wicked in both *Plan A* and *Plan B*.

(8) God would have resurrected King David under *Plan A* to rule as prince.

(9) God gave specific temple plans where He could dwell among His people.

(10) God presented the promises made to THAT Israel which could not be brought about. So, after Christ was rejected, He redefined Israel so the unilateral promises made to Abraham could still be fulfilled.

Now that *Plan A* is behind us, read my book "Daniel Unlocked". You need to know what *Plan B* entails.

My purpose in writing this book isn't to go through Ezekiel and tell you what to believe it means. More importantly, I want to give enough information about Ezekiel so, as you read his entire book, you can understand what it means for yourself. My goal is to give you tools to work with, but don't accept anything because I say it. It is only good when you've taken your own Bible and read what it says. Let the Spirit guide you into all truth. Examine it, consider it, and be like the noble Thessalonians in Berea. They didn't believe what Paul said until they searched the Scriptures to see if his statements were true. I encourage you to do the same.

\* \* \* \* \*

Larry Wilson began investigating the great truths found in the Bible after his return from the Vietnam War. Although his primary focus was understanding Daniel and Revelation, he taught on many other Bible books as well. Larry's study led him to conclude that God's plan to save man can only be understood looking at the Bible as a whole. He believed each Bible writer left clues regarding God's plan of salvation, and as we become acquainted with how they interconnect, we can understand the meaning of God's grace, love, justice, and mercy.

\* \* \* \* \*

Wake Up America Seminars (WUAS) is a nonprofit, nondenominational organization. It is not a church, nor does it have members. Our mission is to proclaim the imminent return of Jesus, and provide study materials so that people can study the Bible for themselves and understand God's Plan to save mankind.

